

Albion Ultrasteel

Unvented Hot Water Cylinders



Exceeding the Standard



STEP UP TO POWERFUL HOT WATER

Ultrasteel...

is the new Albion unvented hot water storage system. Based on the company's experience in giving the trade the products they ask for, the new Ultrasteel is a high quality vessel employing the best in technology. Albion Unvented systems meet the needs of the builder, installer and consumer by providing fast, safe, mains pressure hot water around the home.

Peerless...

performance has been Albion's objective from day one. Fast flow rates, energy efficient insulation, quick recovery coils and the use of an external expansion vessel to reduce maintenance are just a few of the features of Ultrasteel. At 3 bar operation the units meet all modern criteria for fast flow applications.

Priceless...

is the confidence that comes from dealing with the UK's premier supplier of cylinders to the merchant trade - understanding the needs of the merchant and his customer, providing a 25-year guarantee and investing in product, people and promotion.

- Duplex stainless steel for ultimate peace of mind
- 25-year guarantee on stainless shell
- High flow rate controls - ideal for multiple bathrooms and powerful showers
- Fast reheat and high insulation values resulting in high efficiency
- A complete package - just add pipework
- Direct and Indirect models
- 6 sizes: 120-300 litres
- Solar models also available



QUALITY INSIDE AND OUT

Choose Albion Ultrasteel.

Mains Pressure Hot Water - Powerful showers

High Flow Rates - Baths fill very quickly
- Ideal for multiple bathrooms
- Powerful showers

Fast Reheat - Hot water quickly available

Very Well Insulated - Low heat loss
- Economical to run

Attractive Steel Finish Case - Smart, tough and wipe clean

Low Maintenance - No hidden costs

25-Year Guarantee - Peace of mind

Duplex Stainless Steel - Superior corrosion resistance and long life
- 100% recyclable

Take a look inside.

We've combined the highest manufacturing standards with proven Duplex stainless steel, tried and tested valves, control sets and thermostats.

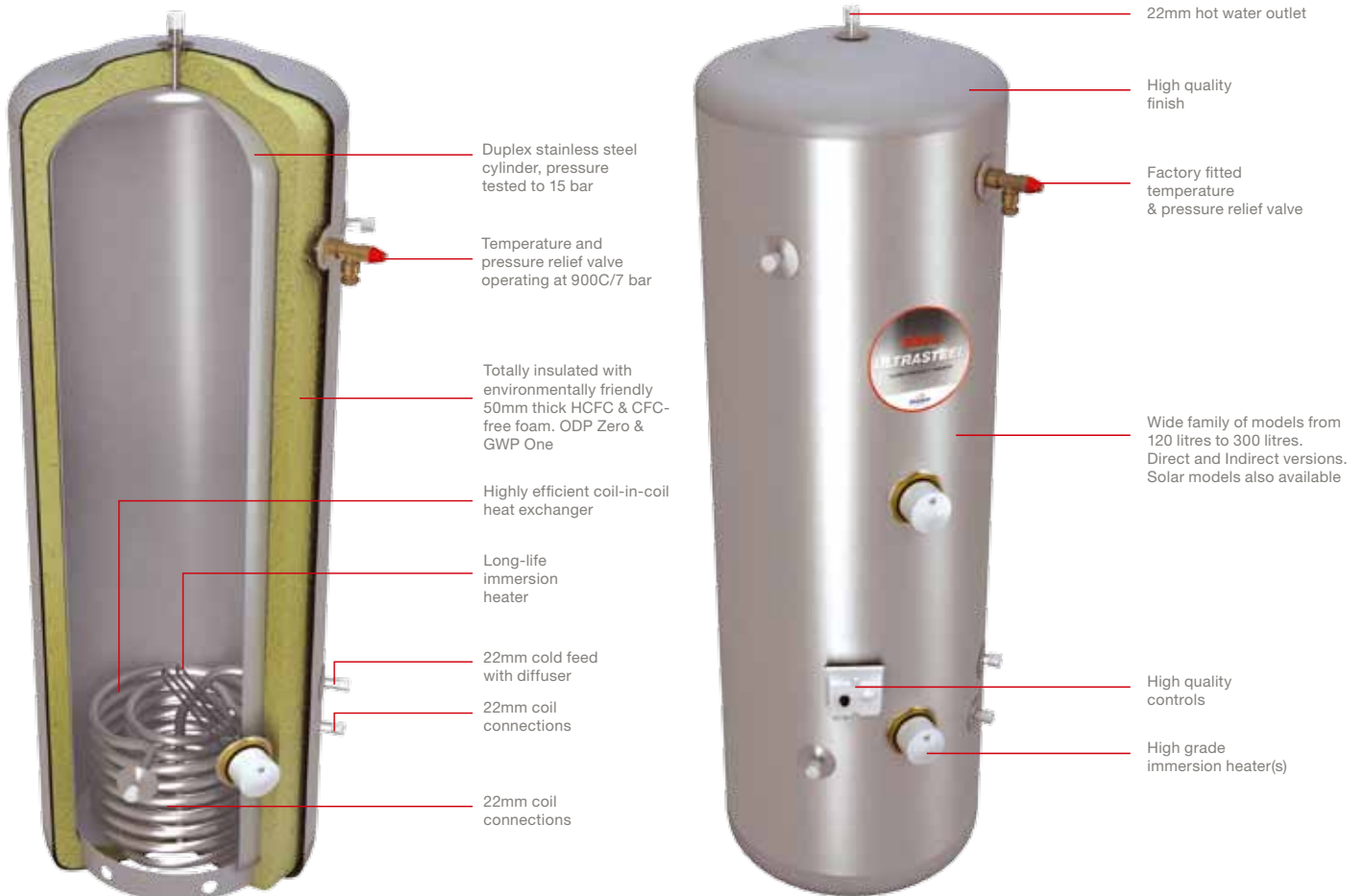

ALL THE FITTINGS YOU NEED...



Expansion Vessel
120 & 150 ltr units - 12 ltr vessel
180, 210 & 250 ltr units - 19 ltr vessel
300 ltr unit - 24 ltr vessel



15/22mm Tundish



Wall Mounting Kit for
Expansion Vessel



Temperature and Pressure
Relief Valve



Dual Thermostat



High Flow Rate
Inlet Control Set



Two Port Valve



Incoloy Long Life 240V x
3kW Immersion Heater



Installation &
Maintenance
Instructions



Benchmark
Log Book

Direct Models (Electric)

- Inlet Control Set.
- Temp & Pressure Relief Valve.
- 15mm / 22mm Tundish.
- Expansion Vessel.
- Wall Mounting Kit.
- 2 x 3 kW Immersion Heaters.
- Installation & Maintenance Instructions.
- Benchmark Log Book.

Indirect Models (Gas, Oil or Electric boilers)

- Inlet Control Set.
- Temp & Pressure Relief Valve.
- 15mm / 22mm Tundish.
- Expansion Vessel.
- Wall Mounting Kit.
- 1 x 3kW Immersion Heater (2 x 3kW on 250 & 300 litre units).
- Two Port Valve.
- Dual Thermostat.
- Installation & Maintenance Instructions.
- Benchmark Log Book.

Direct Solar Models (Electric)

- Inlet Control Set.
- Temp & Pressure Relief Valve.
- 15mm / 22mm Tundish.
- Expansion Vessel.
- Wall Mounting Kit.
- 2 x 3kW Immersion Heaters.
- 1 x Two Port Valve.
- 1 x Single High Limit Stat.
- Installation & Maintenance Instructions.
- Benchmark Log Book.
- 2 x Sensor Pocket Retaining Bungs.

Indirect Solar Models (Alternative Energy Source)

- Inlet Control Set.
- Temp & Pressure Relief Valve.
- 15mm / 22mm Tundish.
- Expansion Vessel.
- Wall Mounting Kit.
- 1 x 3kW Immersion Heater.
- 2 x Two Port Valves.
- 1 x Dual Thermostat.
- 1 x Single Control Stat.
- 1 x Single High Limit Stat.
- Installation & Maintenance Instructions.
- Benchmark Log Book.
- 2 x Sensor Pocket Retaining Bungs.

For Parts and Spares ring
01924 376 026

*Photographs are representative of
components used.

DOMESTIC SELECTION GUIDE

These recommendations are based on the guidelines in BS 6700. Guidance should be sought for unusual applications, e.g. high flow rate showers, large baths etc.

Hot Water Demand	Bedrooms	Indirect	Direct
		Units	Units
1 Standard Bath or Shower	Bedsit/1 Bed	120	150
	2-3 Bed	120	180
	3-4 Bed	150	210
1 Standard Bath	2-3 Bed	120	180
	3-4 Bed	150	210
1 Bath and En-suite	2-3 Bed	150	210
	3-4 Bed	150	210
	4-5 Bed	180	250
2 Standard Baths	2-3 Bed	180	210
	3-4 Bed	180	210
	4-5 Bed	210	250
3 Bathrooms	3-4 Bed	250	300
	4-5 Bed	250	300
	5-6 Bed	300	300

COMMERCIAL SELECTION GUIDE

These recommendations are based on the guidelines in BS 6700. Guidance should be sought for unusual applications, e.g. high flow rate showers, large baths etc.

Typical Commercial Application	Indirect Units
Large House - 6 bed/4 Bathrooms	2 x 210
Guest House - 8 bed/4 Bathrooms	2 x 300
Small Hotel - 8 bed/8 Bathrooms	3 x 210
Sports Pavilion (25 people/4 showers)	2 x 300
Sports Pavilion (25 people/6 showers)	3 x 210
Student House (25 people/3 bathrooms)	3 x 300
Old People's Home (60 beds/10 bathrooms)	5 x 300 each supplying 2 bathrooms

Example illustration.

A school swimming pool has 5 showers in each of two changing rooms. The shower heads are flow-restricted to 9 litres per minute (2/3 of this will be hot water). Usually there are 3 one hour lessons each morning and three each afternoon. Assuming a class size of 30 children.

Maximum demand = 10 shower heads x 9 litres/min = 90 litres/min. This is more than one Ultrasteel can supply. At least two Ultrasteels will be needed to provide this (see flow rate graph) Total demand = 30 children x 6 litres/minute x 5 minute shower each = 900 litres
3x300 litre units will be required

Reheat time has to be a maximum of one hour so it is reheated in time for the next lesson. An AUI300 can reheat its entire contents in 60 minutes with a boiler power of 15kW. So total boiler power required = 45kW. If direct units were used they would have to be fitted with immersion heaters rated at 15kW (typically 1 x 9kW + 1 x 6 kW).



REHEAT PERFORMANCE

Ultrasteel Direct reheat performance

MODEL	REHEAT TIME 2 x 3kW Elements
AUD 120	45 Minutes
AUD 150	61 Minutes
AUD 180	79 Minutes
AUD 210	96 Minutes
AUD 250	112 Minutes
AUD 300	132 Minutes

The reheat performance is measured from 15°C to 60°C after drawing off 70% of the capacity.

Ultrasteel Indirect reheat performance

MODEL	REHEAT TIME	COIL kW RATING
AUI 120	16 Minutes	16.52
AUI 150	18 Minutes	17.16
AUI 180	22 Minutes	19.15
AUI 210	25 Minutes	20.77
AUI 250	28 Minutes	21.96
AUI 300	35 Minutes	22.38

Immersion heaters

SIZE	DIRECT	INDIRECT
120 litre	2 x 3 kW Immersion heaters	1 x 3 kW Immersion heater
150 litre	2 x 3 kW Immersion heaters	1 x 3 kW Immersion heater
180/210 litre	2 x 3 kW Immersion heaters	1 x 3 kW Immersion heater
250/300 litre	2 x 3 kW Immersion heaters	2 x 3 kW Immersion heaters

Immersion Heater options

6kW & 9kW immersion heaters can be specified. In non-domestic (Commercial, Industrial and multiple accommodation units) applications, high quality Titanium immersion heaters are recommended.

Flow rates

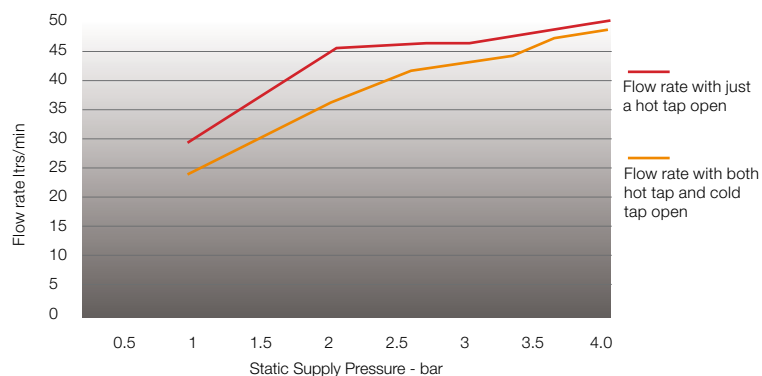

Foam Insulation and Heat Loss

Albion Ultrasteel cylinders have 50mm (nominal) thickness of fire retardant polyurethane foam giving significant gains in standing heat loss values:

CAPACITY	STANDING LOSS (kWH/24 HRS)
120 ltr	1.10
150 ltr	1.38
180 ltr	1.63
210 ltr	1.90
250 ltr	2.21
300 ltr	2.43

In addition our insulation material offers benefits to the 'green' specifier.

- CFC-free and HCFC-free
- Ozone Depletion Potential (ODP) - Zero
- Global Warming Potential (GWP) - One

Technical Specifications

Ultrasteel Direct

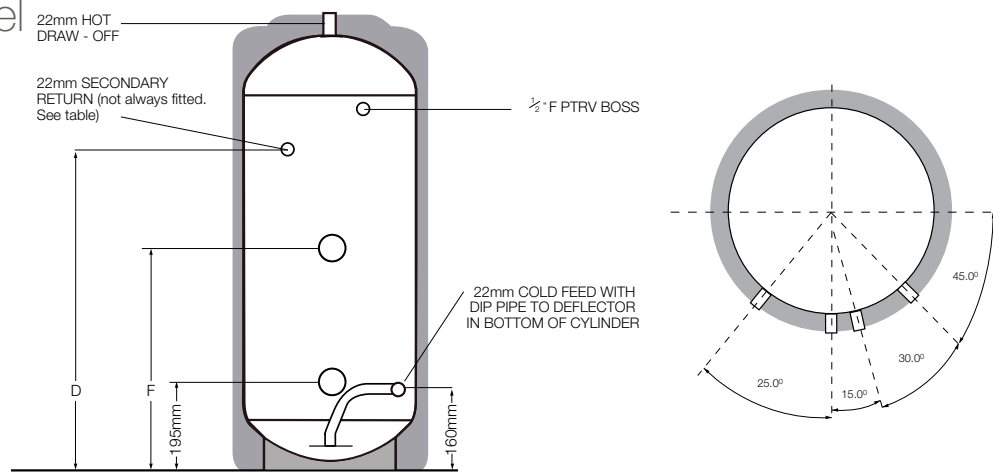

PRODUCT CODE	CAPACITY (Litres)	HEIGHT	DIAMETER	D	F	WEIGHT (Kg - EMPTY)	WEIGHT (Kg-FULL)
AUD 120	120	906	550	N/F	510	30	150
AUD 150	150	1093	550	N/F	610	35	185
AUD 180	180	1281	550	N/F	710	40	220
AUD 210	210	1469	550	1000	810	45	255
AUD 250	250	1719	550	1250	950	50	300
AUD 300	300	2032	550	1500	1100	55	355

All dimensions are in mm and are of the cased unit. N/F = not fitted

Ultrasteel Indirect

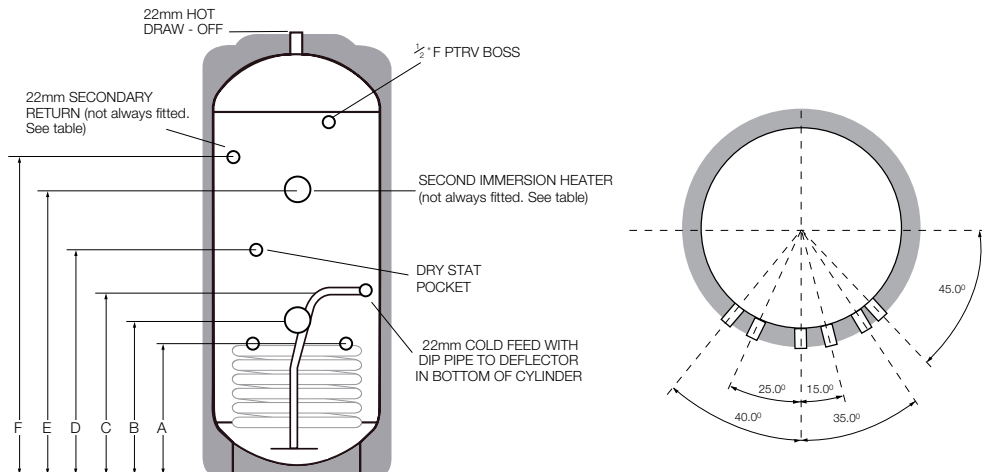

PRODUCT CODE	CAPACITY (Litres)	HEIGHT	DIAMETER	A	B	C	D	E	F	WEIGHT (Kg - EMPTY)	WEIGHT (Kg-FULL)
AUI 120	120	906	550	290	330	390	345	N/F	N/F	35	155
AUI 150	150	1093	550	330	370	465	385	N/F	N/F	40	190
AUI 180	180	1281	550	330	370	465	385	N/F	N/F	45	225
AUI 210	210	1469	550	365	405	465	465	N/F	1150	50	260
AUI 250	250	1719	550	365	405	465	560	950	1400	55	305
AUI 300	300	2032	550	365	405	465	660	1100	1600	60	360

All dimensions are in mm and are of the cased unit. N/F = not fitted

ALBION ULTRASTEEL SOLAR UNVENTED CYLINDERS

Albion Ultrasteel Solar cylinders have been designed specifically with Solar applications in mind. Featuring a purpose-designed solar coil, which allows maximum heat transfer of solar energy into the stored water, the cylinders are suitable for use with a wide range of solar systems now available in the UK and are an efficient and environmentally friendly way of providing Domestic Hot Water. Ultrasteel Solar cylinders also offer the benefit of mains pressure hot water – powerful showers and fast filling baths.

Ultrasteel Solar cylinders are available in a range of sizes from 180 to 300 litres and in Direct or Indirect versions. Ultrasteel Solar cylinders are manufactured from high grade Duplex stainless steel and come with a 25-year fully transferable Guarantee on the inner container.

Ultrasteel Solar Cylinders are designed to accept heat input from a renewable/sustainable (i.e. Solar) heat source. Where this input does not fully meet the desired temperature a guaranteed quantity of water can be heated to an acceptable temperature by the householders' traditional heat source of gas, oil or electricity.

The Domestic Heating Compliance Guide document L1A and L1B provides excellent advice in sizing both cylinder designated solar areas and heat exchangers to the surface area of the solar collectors. Using this guide Albion are able to offer sizing advice for specification.

Water Capacities (Litres)

Model	Designated Solar Volume	Fossil Fuel Volume	Total Capacity
AUSD 180 / AUSI 180	55	125	180
AUSD 210 / AUSI 210	65	145	210
AUSD 250 / AUSI 250	90	160	250
AUSD 300 / AUSI 300	100	200	300

Lower (Solar) Coil Specification

Model	Surface Area (m ²)	Fluid Content (litres)
AUSD 180 / AUSI 180	0.670	3.687
AUSD 210 / AUSI 210	0.860	4.826
AUSD 250 / AUSI 250	0.860	4.826
AUSD 300 / AUSI 300	0.860	4.826

NB: The total detail of Domestic Heating Compliance Guide document should be consulted prior to specifying product or commencing design.

Maximum Nett Surface Area of Collector Panel (m²)

As detailed in Domestic Heating Compliance Guide.

Model	Solar Pump Speed	
	< 0.5LPM	> 0.5LPM
AUSD 180 / AUSI 180	3.35	6.70
AUSD 210 / AUSI 210	4.39	8.78
AUSD 250 / AUSI 250	4.39	8.78
AUSD 300 / AUSI 300	4.39	8.78

In addition our insulation process offers benefits to the 'green' specifier.

Ozone Depletion Potential (ODP) ZERO

Global Warming Potential (GWP) ONE

Technical Specifications

Ultrasteel Solar Direct

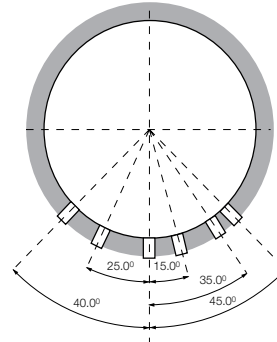
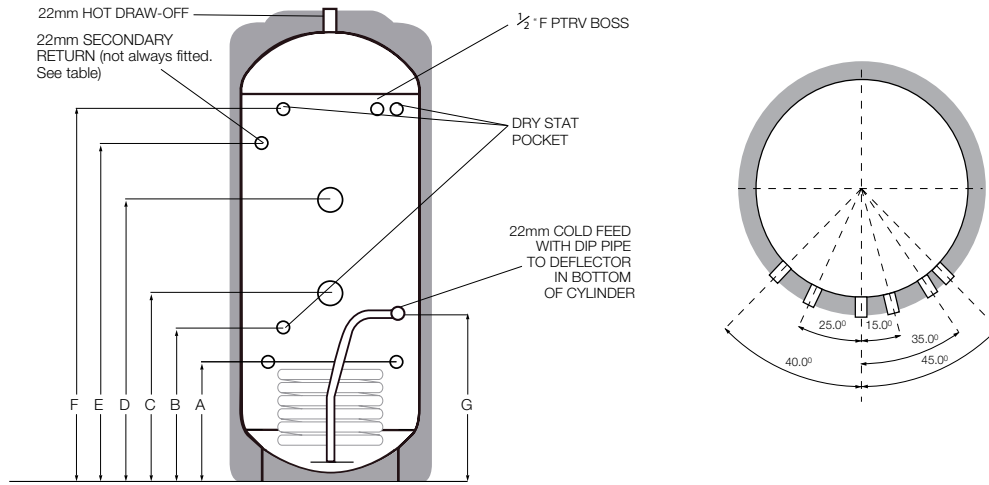

PRODUCT CODE	CAPACITY (Litres)	HEIGHT	DIAMETER	A	B	C	D	E	F	G	WEIGHT (Kg - EMPTY)	WEIGHT (Kg-FULL)
AUSD 180	180	1281	550	290	345	445	710	N/F	1080	390	45	225
AUSD 210	210	1469	550	365	420	500	810	1150	1268	465	50	260
AUSD 250	250	1719	550	365	420	670	1045	1400	1518	465	55	305
AUSD 300	300	2032	550	365	420	670	1100	1600	1831	465	60	360

All dimensions are in mm and are of the cased unit. N/F = not fitted

Ultrasteel Solar Indirect

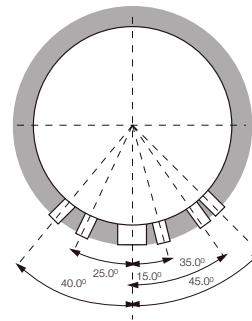
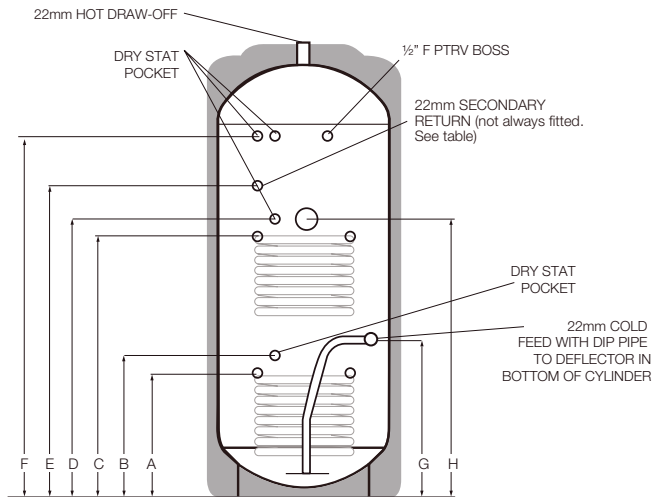

PRODUCT CODE	CAPACITY (Litres)	HEIGHT	DIAMETER	A	B	C	D	E	F	G	H	WEIGHT (Kg - EMPTY)	WEIGHT (Kg-FULL)
AUSI 180	180	1281	550	290	345	674	729	N/F	1080	390	725	50	230
AUSI 210	210	1469	550	365	420	779	834	1150	1268	465	830	55	265
AUSI 250	250	1719	550	365	420	950	1005	1400	1518	465	1000	60	310
AUSI 300	300	2032	550	365	420	979	1034	1600	1832	465	1030	65	365

All dimensions are in mm and are of the cased unit. N/F = not fitted

Products List

Kingspan offer a complete range of renewable energy and related products for both domestic and commercial applications. Our complete solar package solutions include initial advice, professional design specifications and technical assistance through to a network of fully trained Kingspan Solar Accredited Installers who are kept up-to-date with the latest regulations and available grants.

Our range of products consists of:

Albion Exceeding the Standard

Albion Water Heaters manufacture copper cylinders for Domestic Hot Water storage in a variety of sizes and patterns. Primarily a business-to-business company, it supplies its products to plumbers and builders merchants around the country.

Albion copper cylinders are specially designed for use in open vented hot water systems. They are designed to heat up quickly and to retain their heat for long periods. They are available in various combinations of connections to suit individual requirements. Range of products includes Centurion Eco and Superduty HE Eco – indirect twin coil cylinders designed for use with renewable energy sources, such as solar. Installation of Albion Eco cylinders can now be grant assisted.



Albion Manchester Calorifiers Exceeding the Standard

Albion Water Heaters and Manchester Calorifiers design and manufacture a large range of open vented and unvented calorifiers for commercial and industrial use in copper, stainless steel and mild steel. They also offer marine calorifiers and hot water provision for light commercial vehicles. All products feature high quality, durability and exceptional performance.

For maximum efficiency, units can be custom-designed for each specific application. A renewable heat source, e.g. solar panels, can also be incorporated into the system and sized to meet the heating and hot water requirements of the property.



Kingspan Climate^{❄️}

This silent solar powered cooling/heating system is perfect for hotter Mediterranean-style climates. The Kingspan Climate package includes the ClimateWell, premium quality Thermomax vacuum tube collectors, controllers and a Kingspan cylinder.

Compact and incredibly cheap to run, the Kingspan Climate can also provide heating for domestic hot water and swimming pools.



Albion AEROCYL

Albion Aerocyl is the new range of copper unvented hot water cylinders and buffer tanks. The cylinders have been designed specifically to be installed in conjunction with a heat pump only or a solar thermal system and additional input from a heat pump. Manufactured from high grade copper, Aerocyl unvented cylinders feature energy efficient, CFC and HCFC-free foam insulation for low standing heat loss and are environmentally friendly way of providing Domestic Hot Water.

Aerocyl buffer tank is integrated into the space heating system when additional volume of hot water is required to provide smooth and uninterrupted operation of a heat pump and prevent the radiators or underfloor heating from cooling during the heat pump defrost cycle. They are available for both open vented and sealed systems in a range of capacities to suit different size heat pumps available in the UK.



Kingspan SOLAR

Kingspan Solar provides the commercial and domestic markets with an ultimate solar package, custom-designed to suit requirements of each individual application.

The Package incorporates high quality flat plate solar thermal panels or high performance Thermomax evacuated tube solar collectors. The system can incorporate the latest condensing boiler technology, underfloor heating or the traditional radiator system. It is then coupled to a high performance Albion Ultrasteel Duplex stainless steel solar cylinder. The package includes all components required to complete the installation.



Albion is a market leader in the manufacture and supply of quality hot water systems.

Specification summary...



Materials

Inner shell - Duplex Stainless Steel
Coil - 22mm Diameter Stainless Steel
Bosses - Stainless Steel
Every Ultrasteel cylinder is water tested to a pressure of 15 bar.



Insulation

Fire retardant polyurethane foam, nominal thickness 50mm.
The foam is CFC-Free and HCFC-Free.
The foam has an Ozone Depletion Potential of Zero and a Global Warming Potential of One.



Casework

Zintec corrosion proofed steel throughout
Durable, metallic finish outer casing.



Anode

None fitted/none required



Expansion Vessel

12 Litre size with 120 and 150 Litre models
19 Litre size with 180, 210 and 250 Litre models
24 Litre size with 300 Litre model



Control Settings

Pressure Reducing Valve - 3 Bar
Expansion Relief Valve - 6 Bar
Pressure and Temperature Relief Valve - 7 Bar/90°C
High Limit Thermostat in Dual Thermostat - 85°C
High Limit Thermostat in Immersion Heater - 85°C



Immersion Heater

1 1/4" BSP Parallel Threaded Head
Long Life Incoloy Sheathed Low Noise Element 14" Long
Long Life Incoloy Sheathed Thermostat Pocket 11" Long
Brazed Construction
Combined Thermostat and Safety Cut-Out
Element Rating 3kW at 240V A/C



Approvals

WRAS Approved to the Water Regulations
WRc-NSF Approved to Building Regulations G3 & L
CE Compliant and fitted with a BEAB Approved Immersion Heater

OHSAS 18001

Guarantee Terms

The Ultrasteel's stainless steel vessel carries a 25-year guarantee against faulty materials or manufacture provided that:
It has been correctly installed as per the Installation Instructions and all the relevant standards, regulations and codes of practice in force at the time.
It has not been modified in any way, other than by Albion.
It has not been misused, tampered with or subjected to neglect.
The system is fed from the public mains water supply.
It has only been used for the storage of potable water.
It has not been subjected to frost damage.
The unit has been serviced annually.
The Benchmark Log Book has been filled in after each annual service.
The guarantee period starts from the date of purchase.
Please note that invoices for servicing may be requested to prove that the unit has been serviced annually.
The expansion vessel and cold water controls supplied with the Albion Ultrasteel carry a 5-year guarantee.
All other components fitted to/or supplied with the unit carry a 2-year guarantee.
Exclusions – The Guarantee does not cover:
The effects of scale build up.
Any labour charges associated with replacing the unit or its parts.
Any consequential losses caused by the failure or malfunction of the unit.

Albion Water Heaters, part of Kingspan Group plc, is a major manufacturer of Domestic Hot Water storage systems in the UK and offers the trade products backed by the service and technical development skills that only a company of its size can.

All sites are licensed to British Standards quality assurance BS EN ISO 9001 : 2000 and Albion is a BSI registered firm. This means that all manufacturing plants are monitored by an independent inspectorate and the quality systems employed by Albion meet the stringent requirements set down.

Specifiers, stockists and users can depend on Albion for consistent quality and supply. Albion continues to develop energy saving and innovative hot water products for domestic and commercial applications.

Kingspan Hot Waters Systems Ltd have a policy of continuous product development and may introduce product modifications from time to time. As a consequence details given in this brochure are subject to alteration without notice.



Hot Water Systems

Albion Water Heaters

Station Road, Caythorpe, Nr. Grantham, Lincolnshire NG32 3EW

T: 01400 272726 F: 01400 273508

Technical Helpline: 0845 260 7260 Technical Faxline: 0845 260 7261

www.albionwaterheaters.com

www.kingspanhws.com

Issue 06
July 2010