

RANGE

Tribune HE Unvented Hot Water Cylinders Installation and Maintenance Instructions

Issue 14 May 2011
Part No. BOOKTRIB



IMPORTANT NOTE TO THE INSTALLER

Read these instructions before commencing installation. Unvented cylinders are a controlled service as defined in the latest edition of the building regulations and should only be fitted by a competent person.

The relevant regulations are: England and Wales – Building Regulation G3, Scotland – Technical Standard Handbook Section 4, N Ireland – Building Regulation Part F

After installation the Benchmark Log Book must be completed and left, with these instructions, with the householder for future reference.





INTRODUCTION

The TRIBUNE HE Unvented cylinder is made from Duplex Stainless Steel for excellent corrosion resistance. TRIBUNE HE has a strong rust-proofed steel case and is highly insulated with environmentally friendly foam.

It is available in 7 capacities from 90 – 300 litres and in Direct and Indirect versions. Solar models are available in 4 capacities from 180 - 300 litres, in Direct or Indirect versions.

Slimline cylinders are available in 6 capacities from 60 – 210 litres, in both Direct and Indirect versions. Pre-plumbed units are also available in 6 capacities from 120 – 300 litres, in Indirect version.

TRIBUNE HE is supplied complete with all the necessary safety and control devices needed to connect to the cold water mains. All are pre-adjusted. High quality controls have been selected to combine high flow rate performance with minimum pressure drop to make TRIBUNE HE perform well in all areas, even those with poor water pressure. TRIBUNE HE is WRAS approved to show compliance with Building Regulations G3+L.

STORAGE PRIOR TO INSTALLATION

TRIBUNE HE should be stored in its original packaging in an upright position in an area free from excessive damp.

UNPACKING THE UNIT

TRIBUNE HE COMES COMPLETE WITH ALL THE FITTINGS YOU NEED TO COMPLETE THE INSTALLATION:



Expansion Vessel

- 60, 90, 120 & 150 ltr units - 12 ltr vessel
- 180, 210 & 250 ltr units - 18 ltr vessel
- 300 ltr units - 25 ltr vessel



Dual thermostat



Acetal tundish
15 x 22 mm

Direct Models (Electric)

- Inlet control set.
- Temp & Pressure relief valve.
- 15mm / 22mm Tundish.
- Expansion vessel.
- 2 x 3 kW Immersion heaters.
(1 x 3kW on 60 & 90 ltrs)
- Installation & Maintenance Instructions.
- Benchmark Log Book.

Indirect Models

- (Gas, Oil or Electric boilers)
- Inlet control set.
 - Temp & Pressure relief valve.
 - 15mm / 22mm Tundish.
 - Expansion vessel.
 - 1 x 3kW Immersion Heater (2 x 3kW on 250 & 300 litre units).
 - 1 x Two port valve.
 - Dual Thermostat.
 - Installation & Maintenance Instructions.
 - Benchmark Log Book.



High flow rate inlet control set



Two port valve



Installation & Maintenance Instructions

Direct Solar Models (Electric)

- Inlet control set.
- Temp & Pressure relief valve.
- 15mm / 22mm Tundish.
- Expansion vessel.
- 2 x 3 kW Immersion heaters.
- 1 x Two port valve.
- 1 x Single High limit stat.
- Installation & Maintenance Instructions.
- Benchmark Log Book.
- 2 x Sensor pocket retaining bungs.

Indirect Solar Models

- (Alternative Energy Source)
- Inlet Control set.
 - Temp & Pressure relief valve.
 - 15mm / 22mm Tundish.
 - Expansion vessel hose.
 - 1 x 3kW Immersion Heater.
 - 2 x Two port valves.
 - 1 x Dual Thermostat.
 - 1 x Single Control stat.
 - 1 x Single High limit stat.
 - Installation & Maintenance Instructions.
 - Benchmark Log Book.
 - 2 x Sensor pocket retaining bungs.



Incoloy long life
3 kW immersion
heater



Temperature and
pressure relief valve



Benchmark Log Book

WATER SUPPLY

TRIBUNE HE operates at 3 bar (controlled by the inlet control set) and is capable of delivering over 50 litres per minute. The high quality inlet control set has been designed to make the most of the flow rates available, however the performance of any unvented system is only as good as the mains water supply. The maximum possible water demand should be assessed, taking into consideration that both hot and cold services are supplied simultaneously from the mains.

The water supply should be checked to ensure it can meet these requirements. If necessary, consult the local water company regarding the likely pressure and flow rate availability.

If measuring the water pressure, note that a high static (no flow) mains pressure is no guarantee of good flow availability. In a domestic installation 1.5 bar and 25 l/min. should be regarded as the minimum. The maximum mains pressure that the inlet control set can cope with is 16 bar.

Consideration should be given to upgrading existing ½” (15mm) cold mains pipework to a larger size if the recommended minimum pressure/flow rate is not being achieved.

SITING THE UNIT

TRIBUNE HE can supply outlets above it or at some distance from it. Site the unit to minimise “dead leg” distances, especially to the point of most frequent use.

Outlets above the TRIBUNE HE will reduce the outlet pressure available by 0.1 bar for every 1m of height difference. The unit should be protected from frost. Particular care is needed if siting in a garage or outbuilding. All exposed pipework should be insulated. TRIBUNE HE must be installed VERTICALLY on a flat base capable of supporting the weight of the cylinder when full (see technical specification section for weights). The minimum recommended cupboard size is 650mm square.

Access for maintenance of the valves should be considered. The immersion heaters are 375mm long and care should be taken to ensure that they can be withdrawn for servicing if required. The discharge pipework from the safety valves should fall continuously and terminate safely.

SCHEMATIC DIAGRAM

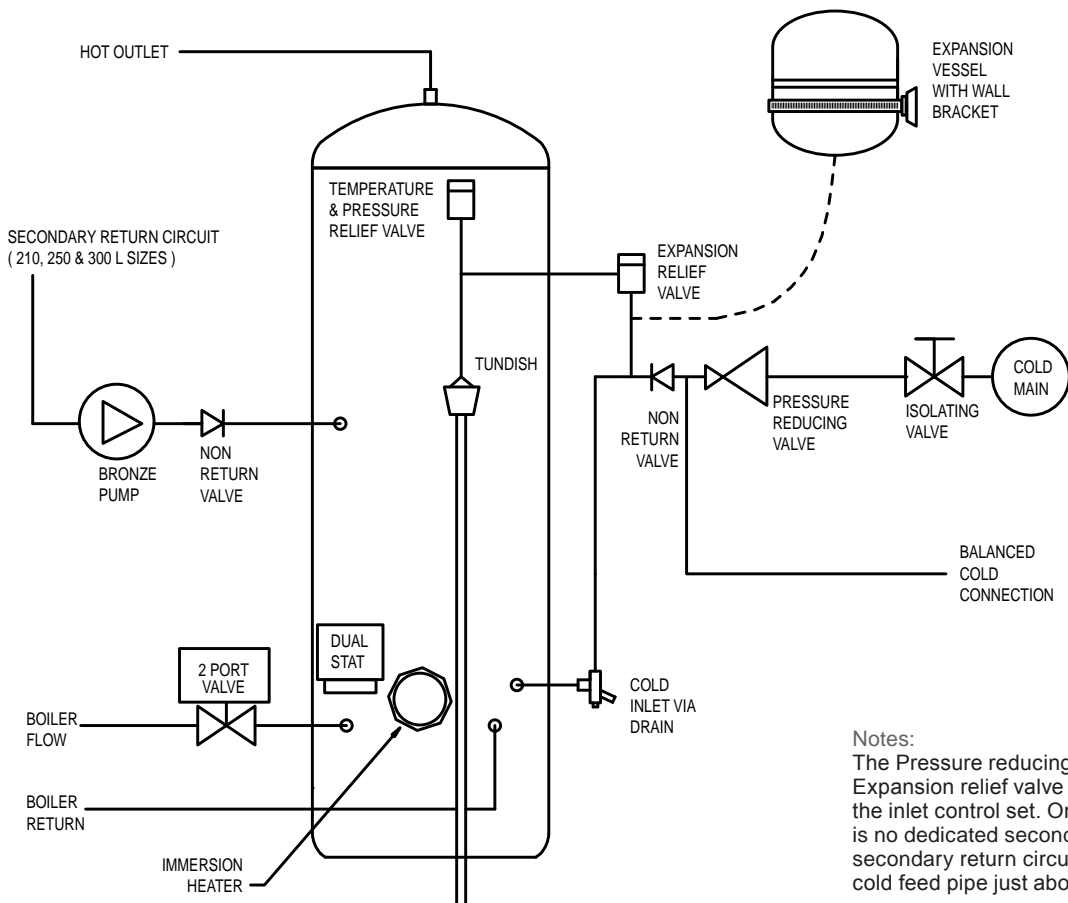

GENERAL INSTALLATION

COLD MAINS PIPEWORK

Run the cold main through the building to the place where the TRIBUNE HE is to be installed. Take care not to run the cold pipe near hot water or heating pipe work so that the heat pick-up is minimized. Identify the cold water supply pipe and fit an isolating valve (not supplied). A 22mm BS1010 stopcock can typically be used but a 22mm quarter turn full bore valve would be better as it does not restrict the flow as much. Do not use "screwdriver slot" or similar valves. Make the connection to the cold feed of the cylinder and incorporate a drain valve. Position the inlet control just ABOVE the Temperature & Pressure Relief Valve (TPRV) mounted on the side of the cylinder. This ensures that the cylinder does not have to be drained down in order to service the inlet control set. Ensure that the arrow points in the direction of the water flow. Select a suitable position for the expansion vessel. Mount it to the wall using the bracket attached to the vessel. Use 22mm copper pipe (not included) to connect to the cold inlet feed pipe from the cold inlet set.



CONNECTING TO THE CYLINDER

All of the pipework connections on the cylinder are 22mm compression and supplied complete with gland nuts and olives, in the Accessory Kit box. Only connect 22mm Table X copper tube to these connections.

Cut the tube with a pipe cutter and ensure no sharp edges or burrs protrude. Slide both gland nut and olive onto the tube and push tube fully home into the connection, ensuring the tube end fully bottoms on the connection recess. Smear the outer wall of the olive with plumbing paste and tighten gland nut in the prescribed manner. Upon filling/commissioning, ensure all connections are completely watertight.

Note:

No control or isolation valve should be fitted between the expansion relief valve and the storage cylinder. The relief valve connections should not be used for any other purpose.

BALANCED COLD CONNECTION

If there are to be showers, bidets or monobloc taps in the installation then a balanced cold supply is necessary. There is a 22mm balanced connection on the inlet control set.

HOT WATER PIPEWORK

Run the first part of the hot water distribution pipework in 22mm. This can be reduced to 15mm and 10mm as appropriate for the type of tap etc. Your aim should be to reduce the volume of the hot draw-off pipework to a practical minimum so that the time taken for the hot water is as quick as possible. Do not use monobloc mixer tap or showers if the balanced cold connection is not provided. Outlets of this type can back pressurize the unit and result in discharge.

PRIMARY COIL CONNECTIONS

Connect the primary connections (Indirect only) using the compression connections provided. The primary circuit must be positively pumped. Gravity circulation is not suitable. Either primary connection may be used as the primary flow. Reheat times are identical either way. The primary circuit can be open vented or sealed, with up to a maximum pressure of 3.5 bar. If you seal the primary circuit an additional expansion vessel and safety valve is required. The boiler may be Gas, Electric or Oil but must be under effective thermostatic control. Uncontrolled heat sources such as some AGA's, back boilers, solid fuel stoves, etc. are NOT SUITABLE. Please contact our Technical department for guidance. Connect the two port zone valve (indirect only) into the primary flow pipework. The direction of flow arrow should be towards the primary flow connection. On twin coil solar cylinders we have provided an extra thermostat boss should you wish to use it. Again a two port zone valve should be fitted (supplied).

For Solar products refer to pages 10-13.

SECONDARY CIRCULATION

TRIBUNE HE can be used with secondary circulation. An appropriate WRAS approved bronze circulator should be used in conjunction with a non-return valve to prevent backflow. On large secondary circulation systems it may be necessary to incorporate an extra expansion vessel into the circuit to accommodate the increased system water volume. Secondary circulation should be avoided on Direct electrically heated units being used on off-peak electricity tariffs.

A secondary return boss is fitted as standard on 210, 250 & 300 ltr units. On smaller sizes, tee into the cold feed pipe above the drain.

IMMERSION HEATERS

Only immersion heaters with a thermal cutout may be used. To help ensure this, the immersion heaters have a special 1¼" thread. They are rated at 3 kW at 240 V and are of a low noise Incoloy construction. They have both a thermostat and a high limit cutout. Please order the correct replacement via ourselves; fitting non-approved immersions may affect your guarantee. When fitting, ensure the 'O' ring is positioned correctly on the head of the immersion heater and lubricate before fitting. Fit it by hand until almost home then tighten gently as the 'O' rings will seal easily. The electrical supply to each immersion heater must be fused at 13A via a double pole isolating switch to BS 3456. The cable must be 2.5mm² heat resistant (85°C HOFRR) sheathed flex complying to BS 6141:1981 Table 8. Do not operate the immersion heater/s until the unit is full of water. Do not operate the immersion heater/s if any sterilisation liquid is in the cylinder as this will cause premature failure. Fit the immersion thermostat (indirect units only) into the thermostat pocket. Complete the wiring – use the appropriate wiring diagrams on page 6.

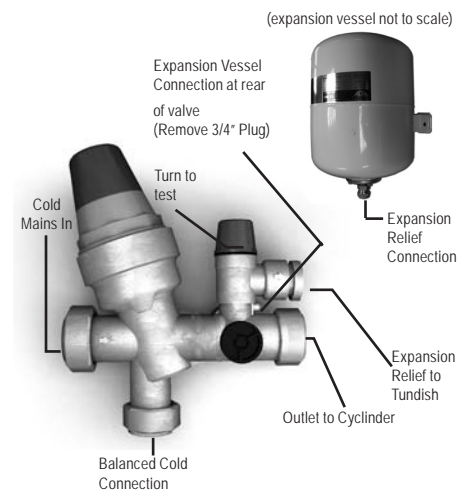

DISCHARGE ARRANGEMENT

Diagram of a typical discharge pipe arrangement (extract from Building Regulation G3)

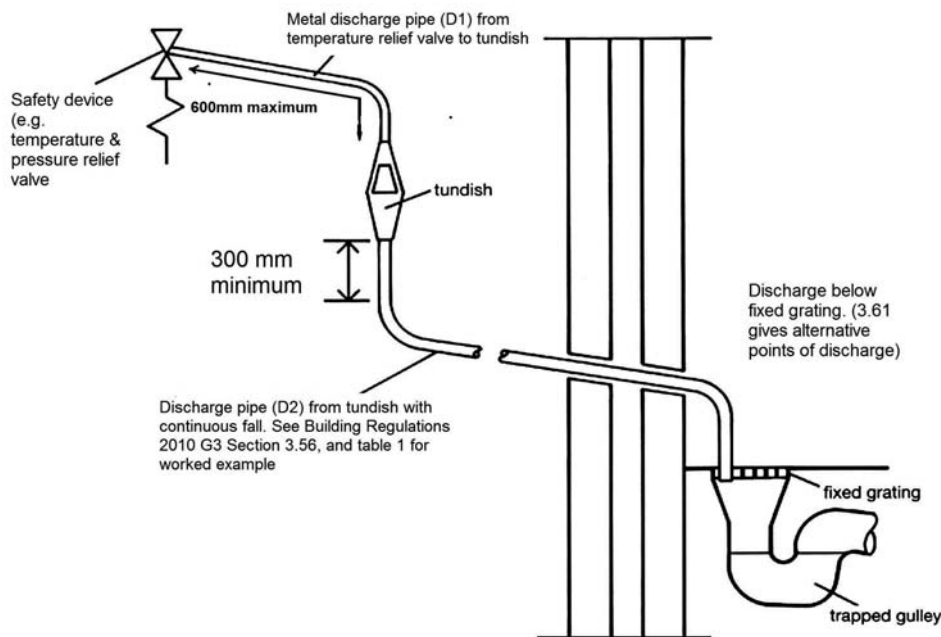

Note: The discharge will consist of scalding water and steam. Asphalt, roofing felt and non-metallic rainwater goods may be damaged by such discharges.

Note: D2 pipe from tundish is now allowed to be installed in soil stacks within premises. This activity is not recommended by Kingspan as discharge from T&P may continue for long periods of time. It is the installers responsibility to ensure the discharge pipework can support the discharge for prolonged periods. If used follow guidance on mechanical seal without water trap given in G3 Building Regulations. As discharge can be in excess of 90°C discharge into plastic pipework is also not recommended.

Position the inlet control group so that the discharge from both safety valves can be joined together via a 15mm end feed Tee (see diagram above). Connect the Tundish and route the discharge pipe. The discharge pipework must be routed in accordance with Part G3 of schedule 1 of the Building Regulations. The information that follows is not exhaustive and if you are in doubt you should seek advice. The two safety valves will only discharge water under fault conditions. When operating normally water will not be discharged. The tundish should be vertical, located in the same space as the unvented hot water storage system and be fitted as close as possible to, and lower than, the safety device, with no more than 600mm of pipe between the valve outlet and the tundish.

Any Discharge should be visible at the tundish. The tundish should be located such that any discharge is visible. In addition, where discharges from safety devices may not be apparent, e.g. people with impaired vision or mobility, consideration should be given to the installation of a suitable safety device to warn when discharge takes place, e.g. electronically operated.

The discharge pipe (D2) from the tundish should:

- A) Have a vertical section of pipe at least 300mm long, below the tundish before any elbows or bends in the pipework.
- B) Be installed with a continuous fall of at least 1 in 200 thereafter.

The discharge pipe (D2) from the tundish should be of metal or other material that have been demonstrated to be capable of withstanding temperatures of the water discharged.

The discharge pipe (D2) should be at least one pipe size larger than the nominal outlet size of the safety device unless its total equivalent hydraulic resistance exceeds that of a straight pipe 9m long i.e. discharge pipes between 9m and 18m equivalent resistance length should be at least two sizes larger than the nominal outlet size of the safety device, between 18 and 27m at least 3 sizes larger, and so on. Bends must be taken into account in calculating the flow resistance. Refer to diagram 1, Table 1 and the worked example. An alternative approach for sizing discharge pipes would be to follow BS6700 Specification for design installation, testing and maintenance of services supplying water for domestic use within buildings and their curtilages.

The discharge pipe (D2) should terminate in a safe place where there is no risk to persons in the vicinity of the discharge. Examples of acceptable discharge arrangements are:

- a. To a trapped gully with the end of the pipe below the fixed grating and above the water seal.
- b. Downward discharges at a low level; i.e. up to 100mm above external surfaces such as car parks, hard standings, grassed areas etc. are acceptable providing that where children play or otherwise come into contact with discharges, a wire cage or similar guard is positioned to prevent contact whilst maintaining visibility.
- c. Discharges at a high level; e.g. in to metal hopper and metal down pipe with the end of the discharge pipe clearly visible or onto a roof capable of withstanding high temperature discharges of water and 3m from any plastic guttering systems that would collect such discharges.
- d. device to warn when discharge takes place.

WORKED EXAMPLE
 The example below is for G1/2 temperature relief valve with a discharge pipe (D2) having 4 No. elbows and length of 7m from the tundish to the point of discharge.
 From Table 1:
 Maximum resistance allowed for a straight length of 22mm copper discharge pipe (D2) from a G1/2 temperature relief valve is: 9.0m. Subtract the resistance for 4 No. 22mm elbows at 0.8m each = 3.2m. Therefore the maximum permitted length equates to: 5.8m. 5.8m is less than the actual length of 7m therefore calculate the next largest size. Maximum resistance allowed for a straight length of 28mm pipe (D2) from a G1/2 temperature relief valve equates to: 14m. As the actual length is 7m, a 28mm (D2) copper pipe will be satisfactory.

Table1
 Sizing of copper discharge pipe 'D2' for a temperature relief valve with a G1/2 outlet size (as supplied).

Size of discharge pipework	Maximum length of straight pipe (no bends or elbows)	Deduct the figure below from the maximum length for each bend or elbow in the discharge pipe
22mm	Up to 9m	0.8m
28mm	Up to 18m	1m
35mm	Up to 27m	1.4m

TYPICAL SCHEMATIC WIRING DIAGRAMS

The diagrams shown relate to the components listed. Other components and other manufacturers' components may vary in their wiring requirements, particularly thermostats. Always refer to manufacturers' instructions which may override the detail in order to function correctly.

WIRING DIAGRAM 2 x TWO PORT ZONE VALVES (S-PLAN)
VARIANT DUAL THERMOSTAT WIRING

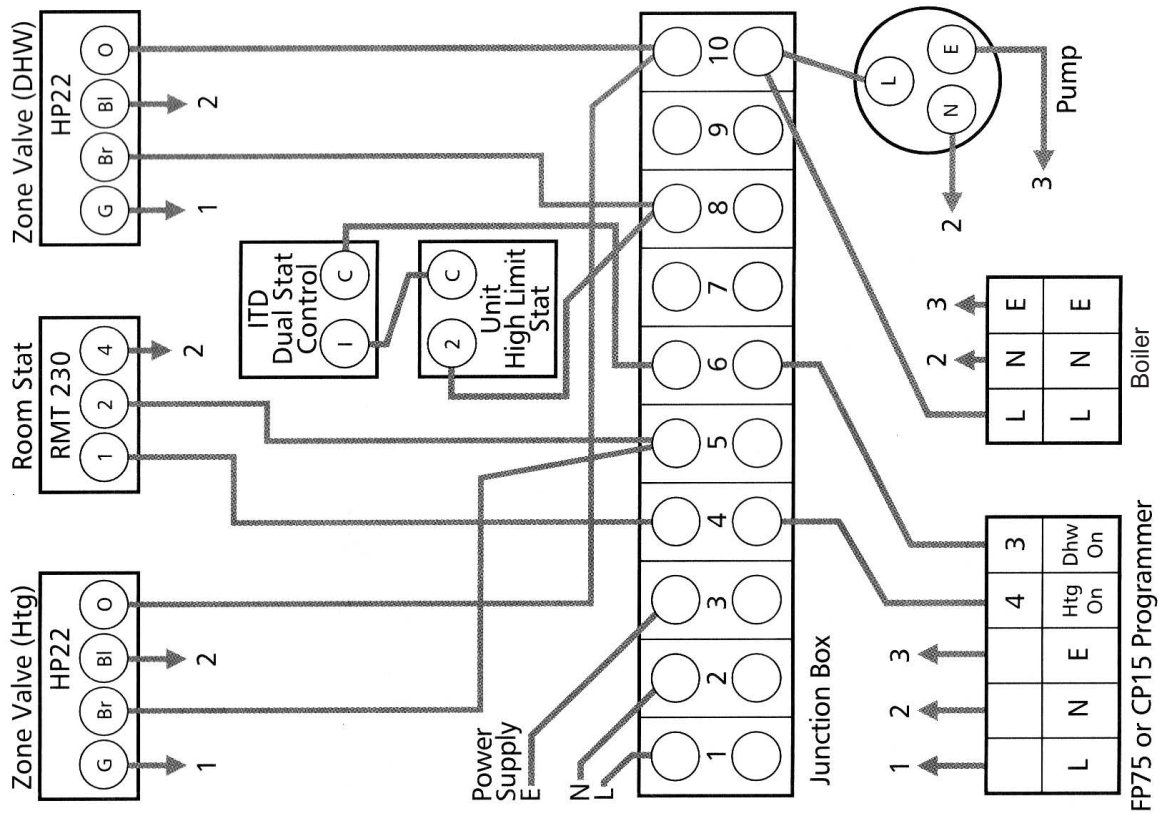

WIRING DIAGRAM THREE PORT MID POSITION VALVE (Y-PLAN) + TWO PORT VALVE
VARIANT DUAL THERMOSTAT WIRING

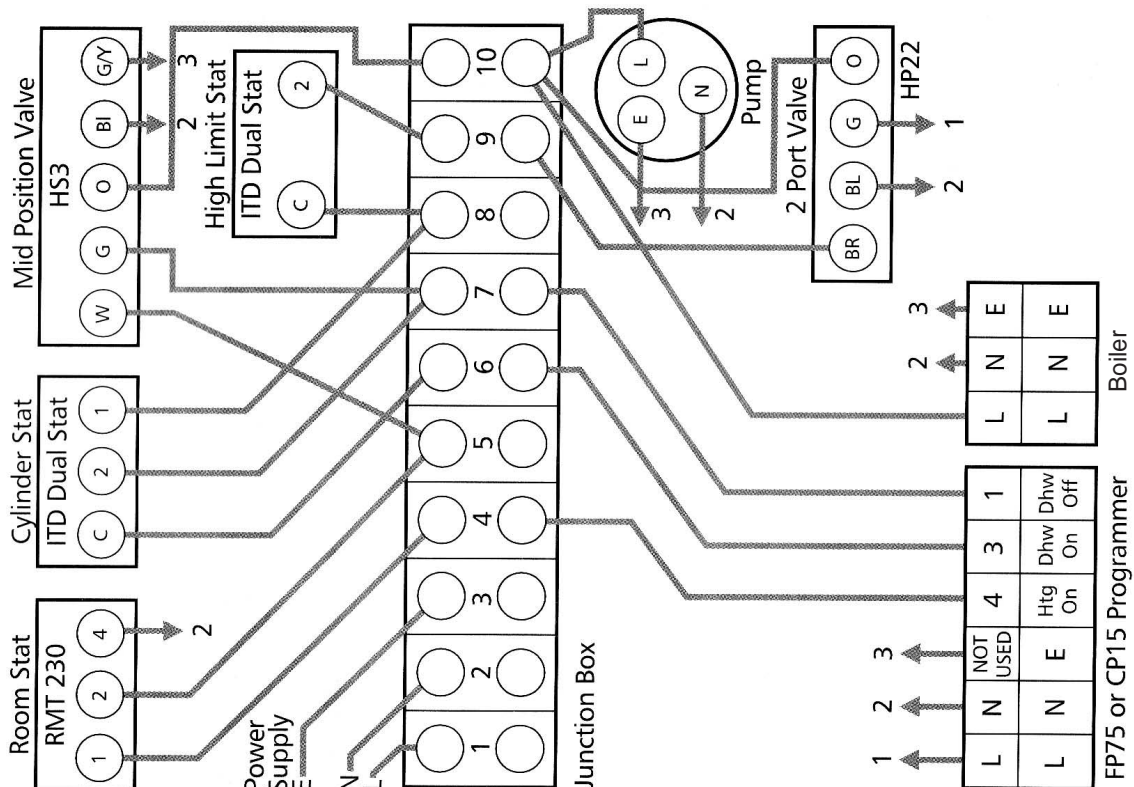

COMMISSIONING

FILLING

Check that the pressure in the expansion vessel is 3 bar (45PSI), i.e. the same as the setting of the pressure reducing valve. The valve is of the car tyre (Schrader) type. Check all the connections for tightness including any factory made connections such as the immersion heater and the temperature and pressure relief valve. Before filling, open the hot tap furthest away from the TRIBUNE HE to let air out. Open the cold main isolation valve and allow the unit to fill. When water flows from the tap allow it to run for a short while to flush through any dirt, swarf or flux residue. Close the tap and open every other hot tap in turn to purge all remaining air.

DIRECT UNITS

After filling with water and after sterilisation liquid has been purged, switch on the power to the immersion heaters and allow the unit to start to heat. The immersion heater is supplied preset at 55°C. Turning fully to + sets to approx 65°C.

INDIRECT UNITS

Consult the boiler manufacturers' commissioning instructions and fill the primary circuit. Ensure the lever on the two port valve is set to the filling position. When full, move the lever back. Switch the programmer to Domestic Hot Water (DHW) and allow the unit to start to heat. Adjust the dial of the dual thermostat to between 55°C and 65°C as required.

STORAGE TEMPERATURE

The recommended storage temperature for both direct and indirect cylinders is 60-65°C. In hard water areas consideration should be given to reducing this to 50-55°C. In many healthcare applications the guidance on Legionella control and safe water delivery temperatures will require storing the water at 60-65°C, distributing at 50- 55°C and using thermostatic mixing valves to control the final temperature.

For details consult the NHS Estates Guidance on safe hot water temperatures.

SAFETY VALVE CHECKS

During heat-up there should have been no sign of water coming from either the expansion relief valve or the temperature/ pressure relief valve. Now hold both of these safety valves fully open, allowing as much water as possible to flow through the tundish. Check that your discharge pipework is free from debris and is carrying the water away to waste efficiently. Release the valves and check that they reseat properly.

SERVICING

GENERAL

Servicing should only be carried out by competent installers and any spare parts used must be purchased from Range Cylinders. NEVER bypass any safety devices or operate the unit without them being fully operational.

DRAINING

Isolate from the electrical supply to prevent the immersion heaters burning out. Isolate the unit from the cold mains. Attach a hose to the draining tap ensuring that it reaches to a level below the unit (this will ensure an efficient syphon is set up and the maximum amount of water is drained from the unit). Open the hot tap closest to the unit and open the draining tap.

WARNING: WATER DRAINED OFF MAY BE VERY HOT!

ANNUAL MAINTENANCE

TRIBUNE HE requires an annual service in order to ensure safe working and optimum performance. It is essential that the following checks are performed by a competent installer on an annual basis. Commonly this is done at the same time as the annual boiler service.

- 1) Twist the cap of the expansion relief valve on the inlet control set and allow water to flow for 5 seconds. Release and make sure it resets correctly. Repeat with the pressure / temperature relief valve. In both cases check that the discharge pipework is carrying the water away adequately. If not, check for blockages etc. and clear. **WARNING: THE WATER DISCHARGED MAY BE VERY HOT!**
- 2) Check that any immersion heaters fitted are working correctly and that they are controlling the water at a temperature between 55°C and 65°C.
- 3) Check the pressure in the expansion vessel is charged to 3 bar. Turn off the water supply to the unit and open a hot tap first. The air valve on expansion vessel is a Schrader (car tyre) type. Air or CO₂ may be used to charge the expansion vessel.
- 4) Unscrew the head on the inlet control set and clean the mesh filter within.
- 5) The Benchmark Log Book supplied with this unit should be updated at each service.

YOUR GUARANTEE MAY BE VOID WITHOUT PROOF OF ANNUAL SERVICING

SPARE PARTS - A full range of spare parts is available from Range Cylinders. Tel: 01924 376026.

TS301 - Inlet control set (pressure reducing valve, strainer and expansion relief valve)	EXPVESB12ALT - 12 litre Expansion vessel (60, 90 120 & 150 ltr sizes)
TS302 - Temperature & pressure relief valve	EXPVESB19ALT- 18 litre Expansion vessel (180 , 210 & 250 ltr sizes)
TS303 - Tundish	EXPVESB24ALT - 24 litre expansion vessel (300 ltr sizes)
TS5 - Two port valve	
TS207 - Dual thermostat	
TS9 - Immersion heater (same on all models)	
T021 - Sensor pocket retaining bungs	
TS27 - Single control stat	
TS28 - Single high limit stat	

FAULT	POSSIBLE CAUSE	SOLUTION
Water escaping from the case	Compression fitting on hot – draw off not sealing	Check/remake joint with sealing paste
Cold water at Hottaps	Direct – immersion heater not switched on or cutout has triggered	Check / reset
	Indirect – boiler not working	Check boiler – consult boiler manufacturers' instructions
	Indirect – motorised valve fault	Check plumbing / wiring to motorised valve
	Indirect – cutout in dual stat has operated	Reset and investigate cause
Water discharges from expansion relief valve	If continual – pressure reducing valve (part of inlet control set) may not be operating correctly	Check outlet pressure from inlet control set is 3 bar.
	If continual – expansion relief valve seat may be damaged	Remove cartridge – check seat and renew if necessary
	If intermittent – expansion vessel charge may have reduced / bladder perished	Check pressure in expansion vessel.Recharge to 3 bar if necessary. If bladder perished replace vessel.
	Unit it being back pressurised	With cylinder cold check pressure in cylinder. If this is the same as the incoming mains pressure then you are getting backfeed. Install a balanced cold supply (see page 4)
Water discharges from temperature & pressure relief valve	Unit has overheated – thermal controls have failed	Switch off power to boiler and immersion heaters. Leave water supply on. Wait until discharge stops. Isolate water supply and replace if faulty
Milky / cloudy water	Oxygenated water	Water from any pressurised system will release oxygen bubbles when flowing. The bubbles will settle out.
No hot water flow	Cold main off	Check and open stopcock
	Strainer blocked in pressure reducing valve	Isolate water supply and clean
	Inlet control set may be fitted incorrectly	Check and refit as required
Noise during hot water draw-off -typically worse in the morning.	Loose airing cupboard pipework	Install extra clips
Hot or warm water from cold tap	If tap runs cold after a minute or so the pipe is picking up heat from heating pipework.	Insulate / re-route

GUARANTEE

The Tribune HE's stainless steel vessel carries a fully transferable 25-year guarantee against faulty materials or manufacture provided that:

- It has been correctly installed as per the Installation Instructions and all the relevant standards, regulations and codes of practice in force at the time.
- It has not been modified in any way, other than by Range.
- It has not been misused, tampered with or subjected to neglect.
- The system is fed from the public mains water supply.
- It has only been used for the storage of potable water.
- It has not been subjected to frost damage.
- The unit has been serviced annually.
- The Benchmark Log Book has been filled in after each annual service.
- The guarantee period starts from the date of purchase and no registration is required.

Please note that invoices for servicing may be requested to prove that the unit has been serviced annually.

The expansion vessel and cold water controls supplied with the Range Tribune HE carry a 5-year guarantee. All other components fitted to/or supplied with the unit carry a 2-year guarantee.

USER INSTRUCTIONS

Your stainless system is automatic in normal use and requires only annual servicing. You should employ a competent installer to perform the annual servicing. Normally this is timed to coincide with the annual boiler service.

IF WATER IS FLOWING FROM THE SAFETY VALVES THROUGH THE TUNDISH THIS INDICATES A FAULT CONDITION AND ACTION IS NEEDED.

If this water is hot, turn the boiler and / or the immersion heater off. Do not turn off the water until the discharge runs cool. The discharge may also stop.

CALL OUT A COMPETENT PLUMBER TO SERVICE THE UNIT.

Tell them you have a fault on an unvented cylinder. We stock all the spare parts they may need (see page 7).

EXCLUSIONS – THE GUARANTEE DOES NOT COVER:

The effects of scale build up.

Any labour charges associated with replacing the unit or its parts.

Any consequential losses caused by the failure or malfunction of the unit.

GUIDANCE IN THE EVENT OF A PROBLEM

If you have a problem in the first year, contact the plumber who fitted the unit. Thereafter contact the plumber who carries out the annual servicing for you. If your Tribune HE develops a leak we will supply you with a new one. We ask for an nominal upfront payment to prevent fraud. We will require the original unit to be returned to us for inspection along with a copy of your Benchmark Log Book. If it is confirmed that it has failed within the terms of the guarantee your upfront payment will be refunded.

If a component part fails within the guarantee period, we will send you a new one without any upfront charge. Credit card details may be taken to prevent fraud. We ask you to post the faulty part back to us within one month by recorded delivery.

If you do not return the part we will charge you for it and for the postage and packing. If your part fails after the guarantee

Technical Specifications

Tribune HE Direct

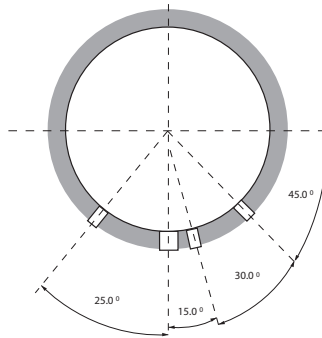
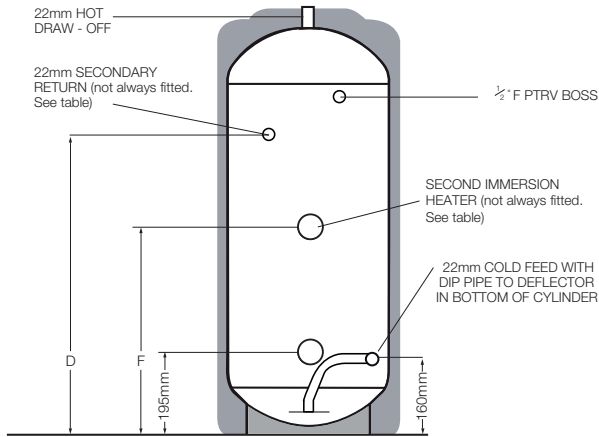

CODE	CAPACITY (Litres)	HEIGHT	DIAMETER	D	F	WEIGHT (Kg-EMPTY)	WEIGHT (Kg-FULL)
TD90	90	718	550	N/F	N/F	25	115
TD120	120	906	550	N/F	510	30	150
TD150	150	1093	550	N/F	610	35	185
TD180	180	1281	550	N/F	710	40	220
TD210	210	1469	550	1000	810	45	255
TD250	250	1719	550	1250	950	50	300
TD300	300	2032	550	1500	1100	55	355

All Dimensions are in mm and are of the cased unit.
N/F = not fitted.

Tribune HE Indirect

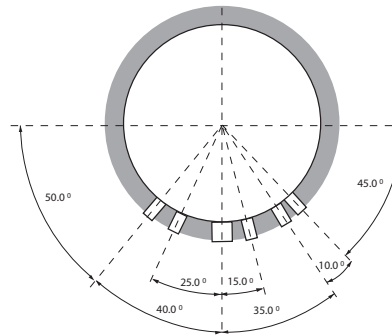
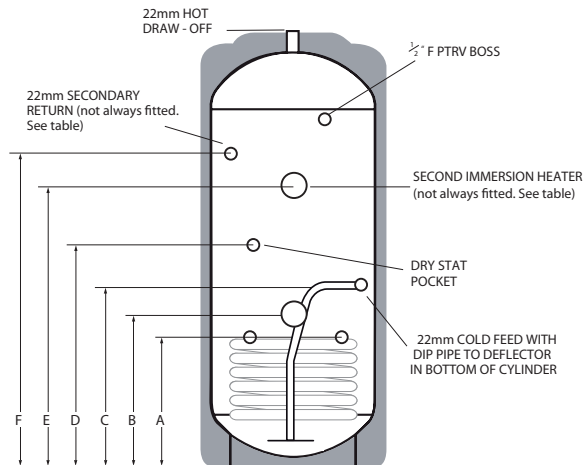

CODE	CAPACITY (Litres)	HEIGHT	DIAMETER	A	B	C	D	E	F	WEIGHT (Kg-EMPTY)	WEIGHT (Kg-FULL)
TI90	90	718	550	290	330	390	345	N/F	N/F	30	120
TI120	120	906	550	290	330	390	345	N/F	N/F	35	155
TI150	150	1093	550	330	370	465	385	N/F	N/F	40	190
TI180	180	1281	550	330	370	465	385	N/F	N/F	45	225
TI210	210	1469	550	365	405	465	465	N/F	1150	50	260
TI250	250	1719	550	365	405	465	560	950	1400	55	305
TI300	300	2032	550	365	405	465	660	1100	1600	60	360

All Dimensions are in mm and are of the cased unit.
N/F = not fitted.

TRIBUNE HE SOLAR UNVENTED DIRECT SINGLE COIL CYLINDER

Detail for the installation of a Solar Unvented Direct cylinder in an electric home.

General

When installing this product it is essential the overall installation meets all current legislation including, in particular, the high limit isolation requirements of Building Regulation G3. This document is designed to assist in achieving that aim.

Water

The potable water connection and tundish discharge connection are to be connected in exactly the manner described in Pages 3 to 7 of this manual.

Immersion Heaters

The standard issue immersion heaters are designed for domestic usage where the lower heater is connected to a low rate off-peak tariff and the upper heater used for occasional top-up purposes. Heaters of this nature are not designed to be permanently live. For usage outside of domestic parameters Titanium immersion elements are recommended.

Solar Connections

The flow and return from the solar heat source are to be connected to the indirect coil. Either primary coil connection (A) may be utilised as the flow or return. The solar sensor, supplied as part of the solar controls, inserts into Pocket B and is held in-situ with the black sensor pocket retaining bung provided. It is necessary to mount the solar pump in the return pipework with the two port valve (supplied with the cylinder) installed between the cylinder and the pump. This valve is of the powered open, sprung closed design and is wired through the high limit stat which inserts into Pocket F. Two wiring options for high limit isolation are provided in Fig. 1 and Fig. 2. The superior option is Fig. 2 which disconnects the pump movement as well as provides valve closure (see pages 11 & 12).

TRIBUNE HE SOLAR UNVENTED INDIRECT TWIN COIL CYLINDER

Indirect twin coil units can be installed in two separate formats:

- a) In a solar powered system with a fossil fuel boiler.
- b) In a system with two independent fossil fuel boilers.

With either format it is essential the overall installation meets all current legislation including, in particular, the high limit isolation requirements of Building Regulation G3. This document is designed to assist in achieving this aim.

UPPER COIL

The upper coil is connected to the fossil fuel boiler as per the instructions for the TRIBUNE HE Unvented Indirect single coil model with the control and high limit thermostat inserted into pocket D (lower diagram page 12). The wiring requirements are as depicted on page 11.

LOWER COIL: SOLAR INSTALLATION

In a solar powered system the lower coil is connected to the solar heat source. Either primary coil connection may be utilised as the flow or return. The solar cylinder sensor, supplied as part of the solar controls, inserts into pocket B (see page 12). It is necessary to mount the solar pump in the return pipework with the two port valve (supplied with the cylinder) installed between the cylinder and the pump. This valve is of the powered open, sprung closed design and is wired through the high limit stat which inserts into pocket F (lower diagram page 12). Two wiring options for high limit isolation are provided in Fig. 1 and Fig. 2 page 11. The control thermostat is not required in a solar installation.

LOWER COIL: TWO BOILER INSTALLATION

Where the lower coil is to be used with a fossil fuel boiler, the pipework requirements are as per that of a TRIBUNE HE Indirect single coil cylinder described earlier in this book. Electrically the control Thermostat inserts into Pocket B (see page 12) to control the boiler input and the high limit stat into Pocket F (lower diagram page 12). The two port valve may be installed into either the flow or return pipework.

TYPICAL SCHEMATIC WIRING DIAGRAM: SOLAR HIGH LIMIT CONTROL

These schematic wiring diagrams refer to high limit control stat provided and the connections are numbered accordingly. Where an alternative is supplied connect as per manufacturers' instructions.

Fig. 1 Isolation of Input: Closure of Two Port Valve

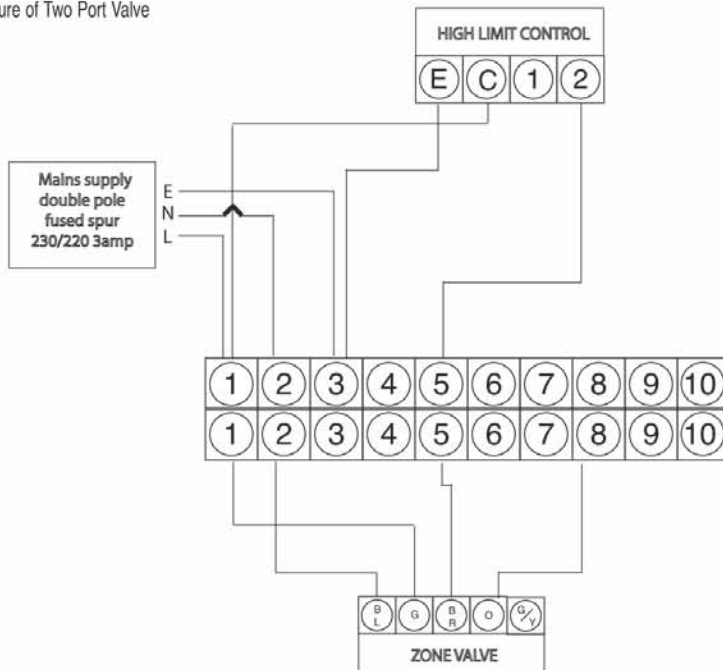
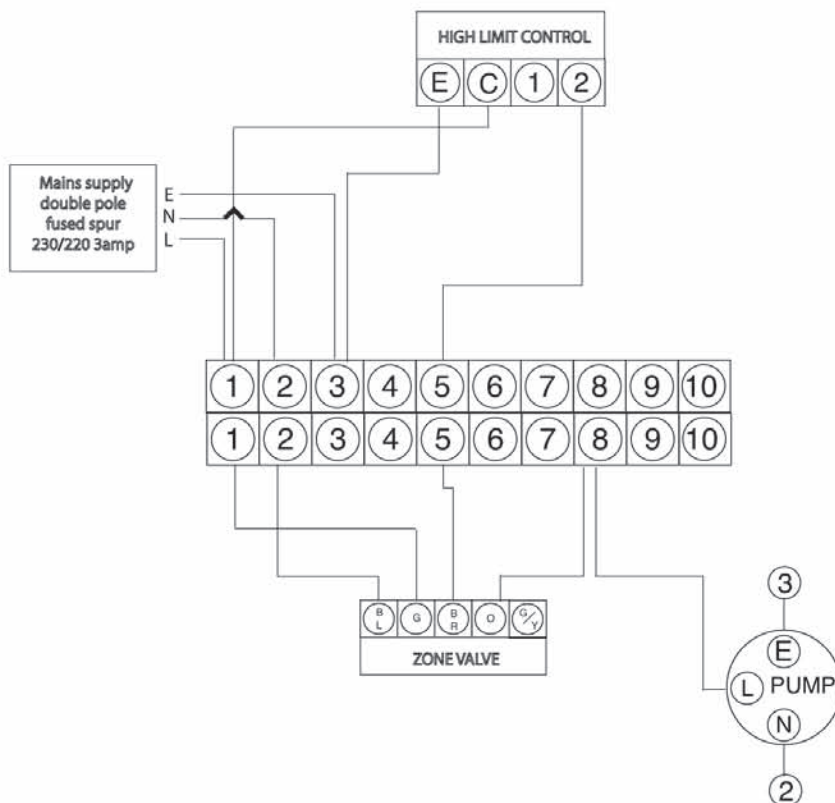
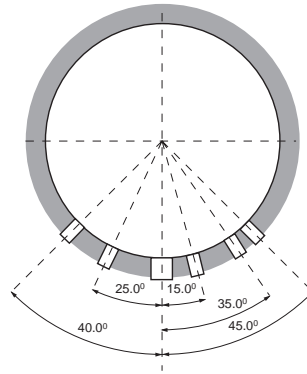
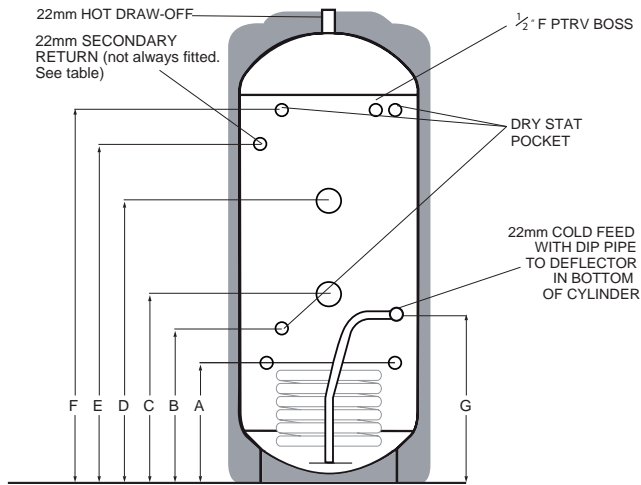

Fig. 2 Isolation of Input: Closure of Two Port Valve & Disconnection Pump



Technical Specifications

Tribune HE Solar Direct



CODE	CAPACITY (Litres)	HEIGHT	DIAMETER	A	B	C	D	E	F	G	WEIGHT (Kg-EMPTY)	WEIGHT (Kg-FULL)
TSS180	180	1281	550	290	345	445	710	N/F	1080	390	45	225
TSS210	210	1469	550	365	420	500	810	1150	1268	465	50	260
TSS250	250	1719	550	365	420	670	1045	1400	1519	465	55	305
TSS300	300	2032	550	365	420	670	1100	1600	1831	465	60	360

All dimensions are in mm and are of the cased unit.

N/F = Not Fitted

Tribune HE Solar Indirect

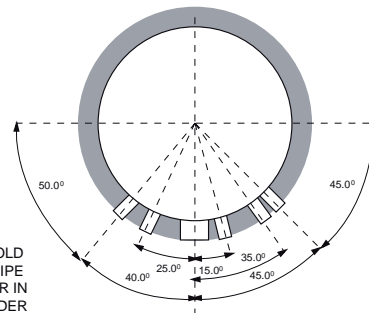
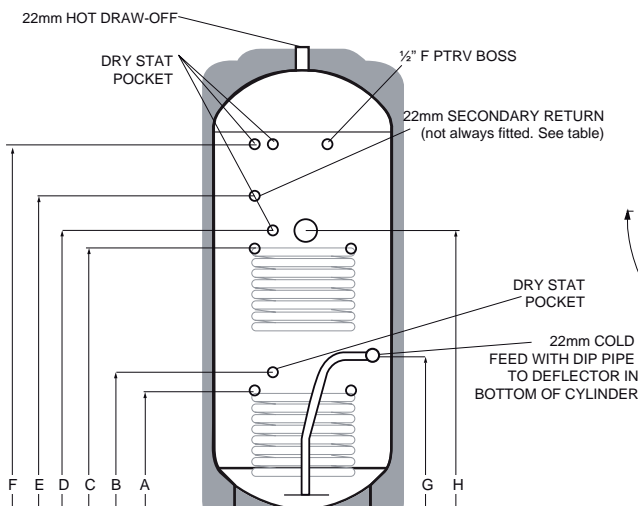

CODE	CAPACITY (Litres)	HEIGHT	DIAMETER	A	B	C	D	E	F	G	H	WEIGHT (Kg-EMPTY)	WEIGHT (Kg-FULL)
TT180	180	1281	550	290	345	674	729	N/F	1080	390	725	50	230
TT210	210	1469	550	365	420	779	834	1150	1268	465	830	55	265
TT250	250	1719	550	365	420	950	1005	1400	1518	465	1000	60	310
TT300	300	2032	550	365	420	979	1034	1600	1831	465	1030	65	365

All dimensions are in mm and are of the cased unit.

N/F = Not Fitted

Range Tribune HE SOLAR UNVENTED CYLINDERS

Range TRIBUNE HE Solar cylinders have been designed specifically with Solar applications in mind. Featuring a purpose designed solar coil, which allows maximum heat transfer of solar energy into the stored water, the cylinders are suitable for use with a wide range of solar systems now available in the UK and Ireland and are an efficient and environmentally friendly way of providing Domestic Hot Water. TRIBUNE HE Solar cylinders also offer the benefit of mains pressure hot water – powerful showers and fast filling baths.

TRIBUNE HE Solar cylinders are available in a range of sizes from 180 to 300 litres and in Direct or Indirect versions. TRIBUNE HE Solar cylinders are manufactured from high grade Duplex stainless steel and come with a 25-year guarantee on the inner container.

TRIBUNE HE Solar cylinders are designed to accept heat input from a renewable/sustainable (i.e. Solar) heat source. Where this input does not fully meet the desired temperature a guaranteed quantity of water can be heated to an acceptable temperature by the householders traditional heat source of gas, oil or electricity.

The Domestic Heating Compliance Guide document L1A and L1B provides excellent advice in sizing both cylinder designated solar areas and heat exchangers to the surface area of the solar collectors. Using this guide Range Cylinders are able to offer sizing advice for specification.

Water Capacities (litres)

Model	Designated Solar Volume	Fossil Fuel Volume	Total Capacity
TT180/TSS180	55	125	180
TT210/TSS210	65	145	210
TT250/TSS250	90	160	250
TT300/TSS300	100	200	300

Lower (Solar) Coil Specification

Model	Surface Area (m ²)	Fluid Content (litres)
TT180/TSS180	0.670	3.687
TT210/TSS210	0.878	4.826
TT250/TSS250	0.878	4.826
TT300/TSS300	0.878	4.826

NB: The total detail of compliance guide document should be consulted prior to specifying product or commencing design.

Maximum Nett Surface Area of Collector Panel (m²)

As detailed in domestic compliance guide

Model	Solar Pump Speed	
	< 0.5LPM	> 0.5LPM
TT180/TSS180	3.35	6.70
TT210/TSS210	4.39	8.78
TT250/TSS250	4.39	8.78
TT300/TSS300	4.39	8.78

In addition our insulation process offers benefits to the 'green' specifier.

Ozone Depletion Potential (ODP) ZERO

Global Warming Potential (GWP) ONE

Technical Specifications

Slimline Units

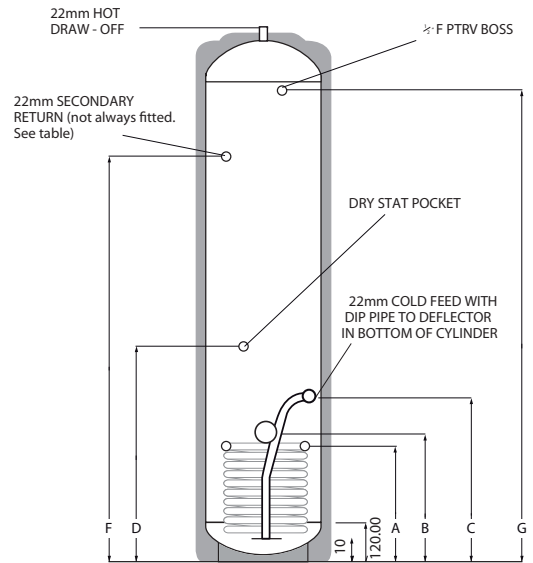
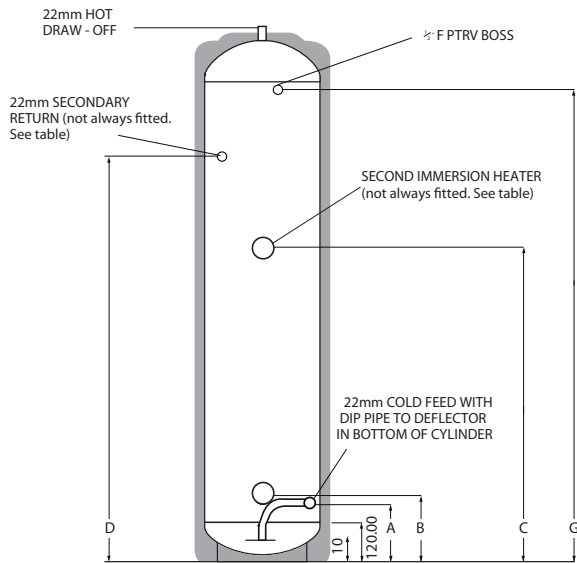

Direct

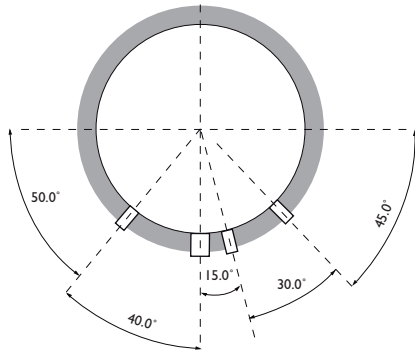

Indirect

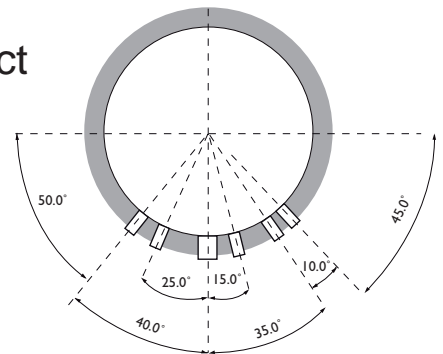

Direct

CODE	CAPACITY (Litres)	HEIGHT	DIAMETER	A	B	C	D	G	WEIGHT (Kg-EMPTY)	WEIGHT (Kg-FULL)
TDS60	60	673	478	175	210	N/A	N/A	483	20	80
TDS90	90	1048	478	175	210	610	N/A	858	29	119
TDS120	120	1236	478	175	210	710	N/A	1046	38	158
TDS150	150	1424	478	175	210	810	N/A	1234	46	196
TDS180	180	1677	478	175	210	910	N/A	1484	54	234
TDS210	210	1987	478	175	210	1110	1500	1797	60	270

Indirect

CODE	CAPACITY (Litres)	HEIGHT	DIAMETER	A	B	C	D	F	G	WEIGHT (Kg-EMPTY)	WEIGHT (Kg-FULL)
TIS60	60	673	478	340	380	440	395	N/A	483	26	86
TIS90	90	1048	478	340	380	440	395	N/A	858	36	126
TIS120	120	1236	478	340	380	440	395	N/A	1046	44	164
TIS150	150	1424	478	380	420	520	520	N/A	1234	52	202
TIS180	180	1677	478	380	420	520	610	N/A	1484	60	240
TIS210	210	1987	478	380	420	520	710	1500	1797	68	278

N/F = not fitted.

All Dimensions are in mm and are of the cased unit.

Technical Specifications

Plug-in, Pre-plumbed Units

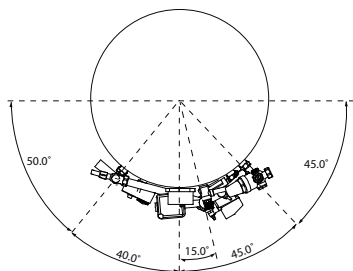
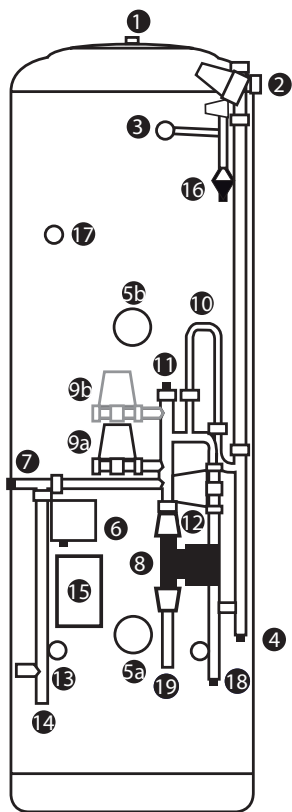

Technical specifications

Connections:

1. 22mm Hot Water Draw Off
2. Inlet Control Set
3. Temperature Relief Valve
4. Cold Feed Drain Elbow
- 5a. Immersion Heater 3kw
- 5b. Immersion Heater 3kw on 250L & 300L cylinders only
6. Twin Thermostat
7. 22mm Auto Bypass Valve
8. Circulating Pump
- 9a. Central Heating Flow 2 Port Valve Zone 1
- 9b. Central Heating Flow 2 Port Valve Optional Zone 2 (Optional)
10. Filling Loop Flexible Hose
11. Manual Bottle Air Eliminator
12. 22mm DHW 2 Port Valve
13. 28mm Return from Radiator Circuit
14. 28mm Return to Boiler
15. Wiring Centre
16. Tundish
17. Secondary Return on 210L, 250L & 300L cylinders only
18. DHW Drain
19. 28mm Flow to Boiler

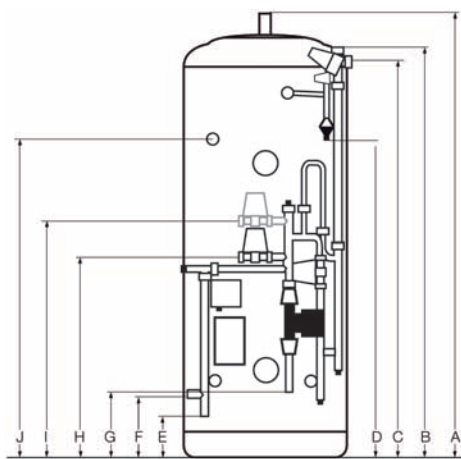

CODE	CAPACITY (Litres)	HEIGHT	DIAMETER	WEIGHT (Kg-EMPTY)	WEIGHT (Kg-FULL)
TI120P	120	906	550	45	165
TI150P	150	1093	550	50	200
TI180P	180	1281	550	55	235
TI210P	210	1469	550	60	270
TI250P	250	1719	550	65	315
TI300P	300	2032	550	70	370

CODE	A Hot Draw Off	B Cold Mains Inlet	C Balanced Domestic Feed	D Discharge to Waste	E Return from Boiler	F Return from Radiators	G Flow to Boiler	H Flow to Central Heating Zone 1	I Flow to Central Heating Zone 2	J Secondary Return
TI120P	922	883	836	573	171	246	102	470	590	N/F
TI150P	1109	1070	1023	760	211	286	140	508	628	N/F
TI180P	1297	1258	1211	948	211	286	320	690	810	N/F
TI210P	1485	1446	1399	1136	246	321	320	690	810	1150
TI250P	1735	1696	1649	1386	246	321	320	690	810	1400
TI300P	2048	2009	1962	1699	246	321	418	784	904	1600

All Dimensions are in mm and are of the cased unit. N/F = not fitted.

TRIBUNE HE IS A MARKET LEADER IN SUPPLY OF QUALITY HOT WATER SYSTEMS.

Specification summary...



OHSAS 18001

Materials

Inner shell - Duplex Stainless Steel
Coil - 22mm Diameter Stainless Steel
Bosses - Stainless Steel
Every TRIBUNE HE cylinder is water tested to a pressure of 15 bar.

Insulation

Polyurethane foam, nominal thickness 50mm.
The foam is CFC-Free and HCFC-Free.
The foam has an Ozone Depletion Potential of Zero and a Global Warming Potential of One.

Casework

Zintec corrosion proofed steels throughout
Durable, stove enamelled, gloss white paint finish

Anode

None fitted/none required

Expansion Vessel

12 Litre size with 60, 90, 120 and 150 Litre models
18 Litre size with 180, 210 and 250 Litre models
25 Litre size with 300 Litre models

Control Settings

Pressure Reducing Valve - 3 Bar
Expansion Relief Valve - 6 Bar
Pressure and Temperature Relief Valve - 7 Bar/90°C
High Limit Thermostat in Dual Thermostat - 85°C
High Limit Thermostat in Immersion Heater - 75°C

Immersion Heater

1 1/4" BSP Parallel Threaded Head
Long Life Incoloy Sheathed Low Noise Element 14" Long
Long Life Incoloy Sheathed Thermostat Pocket 11" Long
Brazed Construction

Combined Thermostat and Safety Cutout
Element Rating 3kW at 240V A/C

Approvals

WRAS Approved to the Water Regulations
WRc-NSF Approved to Building Regulations G3 & L
CE Compliant and fitted with a BEAB Approved
Immersion Heater

Range Cylinders, part of Kingspan Group, is a major manufacturer of Domestic Hot Water storage systems in the UK and offers the trade products backed by the service and technical development skills that only a company of its size can.

All sites are licensed to British Standards Quality Assurance BS EN ISO 9001 : 2008 and Range is a BSi registered firm. This means that all manufacturing plants are monitored by an independent inspectorate and the quality systems employed by Range Cylinders meet the stringent requirements set down. Specifiers, users and stockists can depend on Range for consistent quality and supply. Range continues to develop energy saving and innovative hot water products for domestic and commercial applications.

Kingspan Renewables have a policy of continuous product development and may introduce product modifications from time to time. As a consequence details given in this brochure are subject to alteration without notice.

Issue 14 May 2011
Part No. BOOKTRIB

RANGE

Range Cylinders
Tadman Street, Wakefield WF1 5QU
Tel: 01924 376026 Fax: 01924 385015
Technical Helpline: 0845 260 7260. Technical Fax Line: 0845 260 7261
www.range-cylinders.co.uk
www.kingspan-renewables.co.uk

