

# Kingspan SOLAR

## Flat Plate Collector Installation Manual



## Introduction

Solar hot water systems should be designed and sized correctly before commencing the installation. Proper design will ensure that a system is correctly sized to provide many years of optimised performance and most or all of the required hot water when the most solar radiation is available. However a supplementary heating system such as oil or gas boiler, heat pump or wood boiler is required for months which have less solar radiation.

For large systems, Kingspan provide a system design service to its Accredited Installer Network and technical design consultants. Please visit [www.kingspansolar.com](http://www.kingspansolar.com) to locate an Accredited Installer or distributor in your area.

### Using this guide

Stages of a solar installation are described in the following pages, with illustrations where necessary to explain how to install the relevant components, and contains general recommendations and important safety information.

#### Handling Guidance :

- Heavy goods should not be loaded on top of the collectors or other boxes supplied.
- Care should be taken when opening collectors and boxes to ensure that the product is not scratched and that the glass is not subjected to any sudden shocks.
- Sharp items should not be used to open the collectors or boxes.
- The collectors should only be unpacked when they are ready to be installed.
- The collectors must be transported in a vertical position with a maximum of 7 collector panels per pallet.
- During transportation the collectors must be secured with no other items loaded on top of the collectors.
- Collectors should always be handled carefully and must never be dropped or dragged.

#### Installation Guide :

- Do not leave the solar collector exposed to solar radiation when the solar loop has been drained
- Collectors left exposed and in a dry state must be covered to prevent long term damage.
- A heat dissipation loop (heat dump) is recommended in case where the system may be subject to long periods of stagnation (eg schools, sports clubs, holiday homes ect) – please refer to pages 38-42 of the Technical Design Guide.
- The pipework of the solar collector loop is to be earthed and the collector is to be lightning protected in accordance to local regulations.

For further technical support please contact the following numbers,  
Ireland - 1800 812 718 or UK – 0845 812 0007.

### Health and Safety Precautions

A solar panel installation must be performed in accordance with all Health & Safety legislation and local building/planning regulations for the relevant jurisdiction.

Furthermore, the necessary electrical work required to install control equipment should be undertaken by a qualified electrical contractor.

## Product Information

### Materials

#### Collector Case

The collector case is manufactured from high grade 6063 / 6060 Aluminium. The casing is designed to provide simplicity for mounting and dismounting the system.

#### Collector Insulation

The collector is well insulated using a high temperature resistance insulation that minimizes thermal losses from the base and sides of the collector. The insulation is a mineral rock wool product that is resistant to temperatures up to 650°C (1200 °F) and is resistant to water.

#### Transparent Glass Cover

The glass cover is a 4mm thick low-iron content tempered glass sheet with a textured surface finish that provides a transmission of approx. 91% giving high performance, quality and reliability. This tempered glass (which is also referred to as safety glass) provides excellent resistance to impacts and sudden shocks and in cases of breakage will shatter in a 'safe' manner into small fragments.

### Construction of Collector

The glass is sealed in the collector frame with EPDM and rubber. EPDM is used for sealing and it is resistant to 150°C degrees and the aging effect of the sun. Silicone is applied between the EPDM and glass. Regular rains cleans the glass. In conditions of lacking rain, the glass must be cleaned. It can be cleaned by ordinary cleaners and water. It should be noted that, the cleaner the glass, the more efficient the collector.

### Collector Cross Section

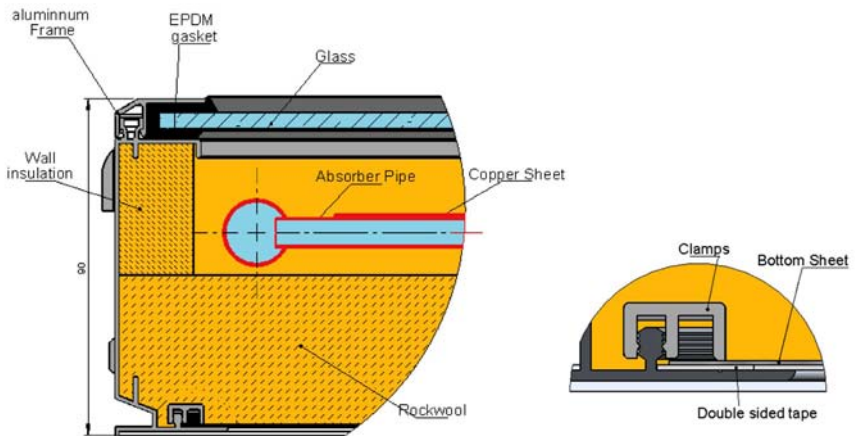
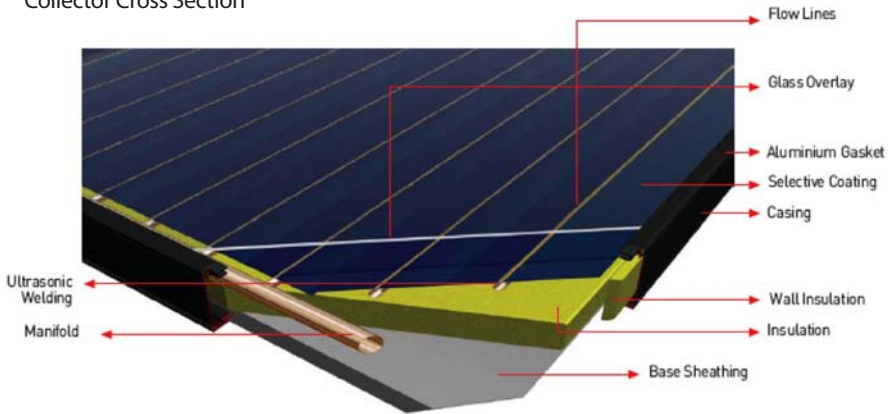

## Technical Specifications

Specification / Type	2510	2108	1808
Dimensions	2006 x 1236 x 105 mm	2006 x 1059 x 105mm	1945 x 946 x 105 mm
Casing Material	Electrostatic Painted Aluminium Case	Electrostatic Painted Aluminium Case	Electrostatic Painted Aluminium Case
Weight	47.5 kg	41.57 kg	37.5 kg
Sealing Material	EPDM & Silicone	EPDM & Silicone	EPDM & Silicone
Casing	Aluminium	Aluminium	Aluminium
Gross Area	2.49 m <sup>2</sup>	2.12 m <sup>2</sup>	1.84 m <sup>2</sup>
Aperture Area	2.28 m <sup>2</sup>	1.93 m <sup>2</sup>	1.65 m <sup>2</sup>
Absorber Area	2.28 m <sup>2</sup>	1.85 m <sup>2</sup>	1.63 m <sup>2</sup>
Absorber Material	Selective Coated Copper	Selective Coated Copper	Selective Coated Copper
Thickness	0.20mm	0.20mm	0.20mm
Absorption level	%95	%95	%95
Thermal Emission Level	%3	%3	%3
Welding Method	Ultrasonic welding	Ultrasonic welding	Ultrasonic welding
Heat Carrier Volume	2.36 liter	1.7 liter	1.27 litre
Diameter of Absorber Tube	8.0 mm	8.0 mm	8.0 mm
Absorber Tube Wall Thickness	0.45 mm	0.45 mm	0.45 mm
Diameter of Header Tube	18 mm	18 mm	18 mm
Header Tube Wall Thickness	0.70 mm	0.70 mm	0.70 mm
Number of Tubes	10	9	8
Tube pitch (mm)	110 mm	110 mm	110 mm
Glass Material	Low Iron Tempered Glass	Low Iron Tempered Glass	Low Iron Tempered Glass
Transmittance of Glass	91%	91%	91%
Thickness of Glass	4 mm	4 mm	4 mm
Insulation Material	Rockwool	Rockwool	Rockwool
Thermal Conductivity	0.037 W/(mK)	0.037 W/(mK)	0.037 W/(mK)
Heat Capacity of wool	0.84 kJ/(kgK)	0.84 kJ/(kgK)	0.84 kJ/(kgK)
Density of wool	52 density	52 density	52 density
Thickness of wool	50 mm	50 mm	50 mm
Efficiency			
eta 0 (zero loss efficiency - $\eta_{0a}$ )	0.732	0.732	0.732
k1 (W/m <sup>2</sup> K) (1 <sup>st</sup> heat loss coefficient - A1a)	3.472	3.472	3.472
k2 (W/m <sup>2</sup> K <sup>2</sup> ) (2 <sup>nd</sup> heat loss coefficient - A2a)	0.008	0.008	0.008
Stagnation Temperature at 1000 W/m and 30°C	211°C	211°C	211°C
Max. Operation Pressure	10 bar	10 bar	10 bar
Test Pressure	20 bar	20 bar	20 bar
Pressure Loss	1.8 bar	1.6 bar	1 bar
Nominal Flow Rate	10.8 L/min/m <sup>2</sup>	0.83 L/min/m <sup>2</sup>	0.93 L/min/m <sup>2</sup>
Base Sheeting	Embossed - finished Aluminium	Embossed - finished Aluminium	Embossed - finished Aluminium
Mounting Mode	In-roof, on-roof, flat roof	In-roof, on-roof, flat roof	In-roof, on-roof, flat roof
Max Load (Positive)	3000 Pa	3000 Pa	3000 Pa
Max Load (Negative)	1000 Pa	1000 Pa	1000 Pa
Solar Keymark	011-751276F	011-751276F	011-751276F
MCS Certification	BSI KM 559829/07	BSI KM 559829/07	BSI KM 559829/07

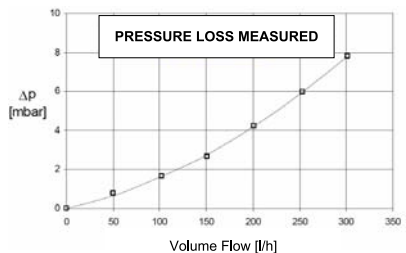
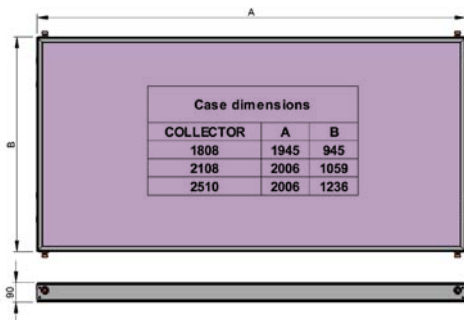

## Mounting the Panel

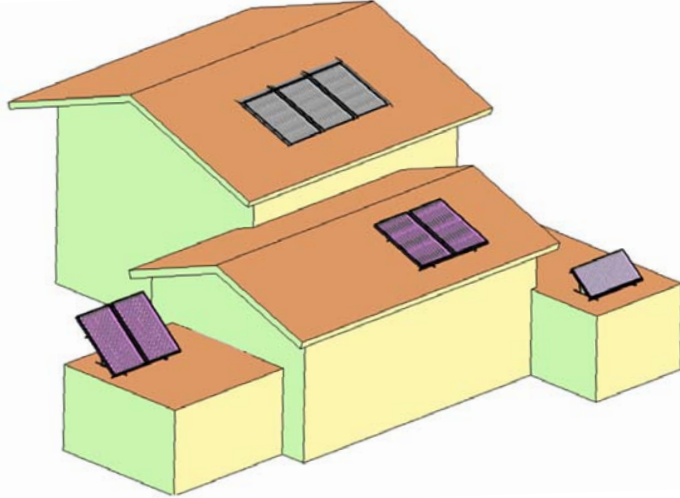

### Slope and direction of the collector on the roof

To get the best efficiency from the solar collector, it must be mounted with the right direction and slope.

### Slope angle $\alpha$

Slope angle  $\alpha$  is the angle between the collector and horizontal (x) axis. The absorber used in the collector can get the most efficient energy when it is mounted as collector axis is absolute vertical to the sun rays. The angle of sun rays change related to hour and seasonal, hence the collectors must be directioned with the right angle and slope. It is practiced that the angle between  $30^\circ$  and  $45^\circ$  are the most ideal angles to mount. The collector must be installed at an angle between  $20^\circ$  and  $90^\circ$  to the horizontal plane.

### Azimuth $\lambda$ angle

Azimuth  $\lambda$  angle means the deflection of the collector axis from south direction, so the angle of the collector which directioned to the south is zero (0). The axis of the collector should be directioned to the south as possible as you can because of the sun rays reflect pick of reflection at noonday. The deviation up to 45 degree to the south can be accepted by the way.

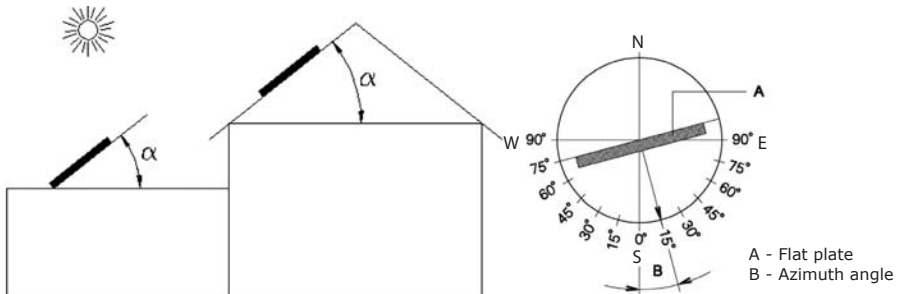

A - Flat plate  
B - Azimuth angle

# FLAT ROOF

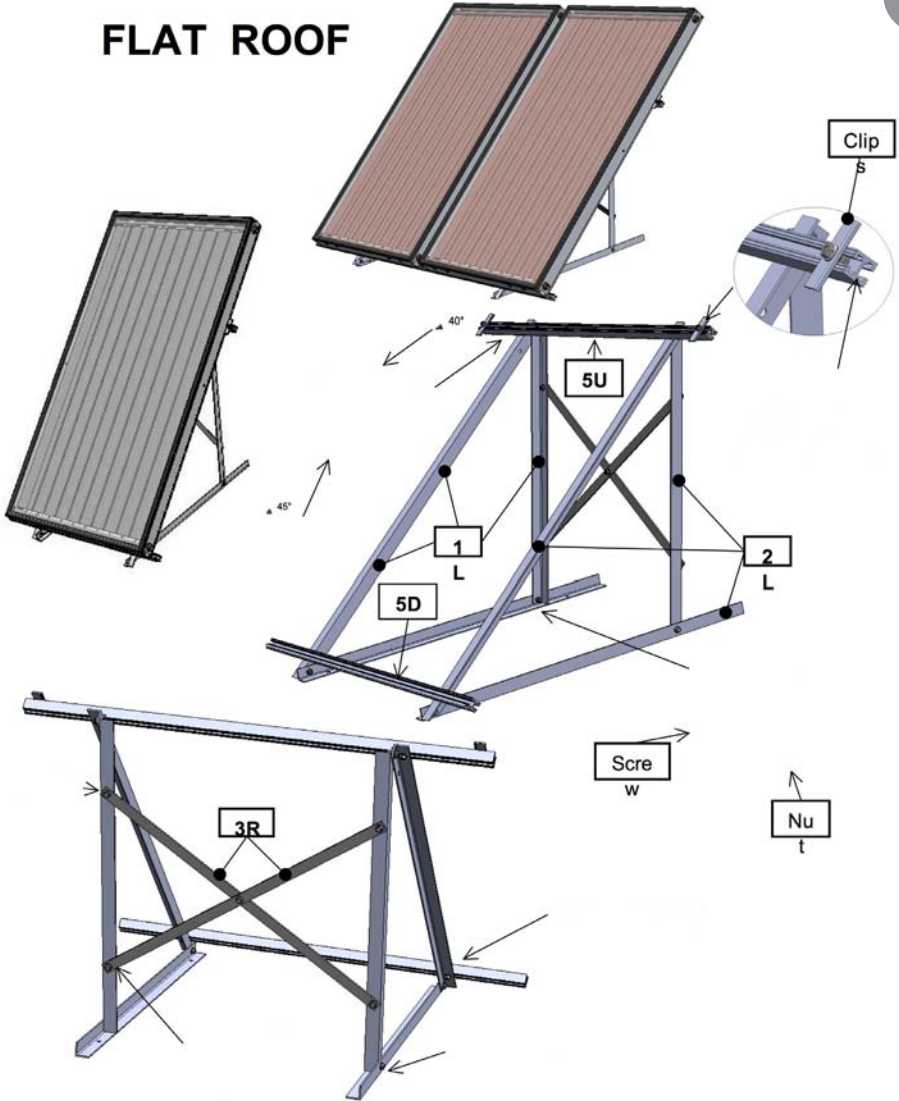

## Flat - Roof Dimensions

1 Collector 1808		
No	Unit	Dimensions
1L	1	3 screwed pieces of (1490 - 1190- 980) X 30 X 30 mm
2L	1	3 screwed pieces of (1490 - 1190- 980) X 30 X 30 mm
3R	1	2 screwed pieces of 980 X 30 X 5 mm
5U	1	1050 X 30 X 30 mm
5D	1	1050 X 30 X 30 mm
Screw	17	M10 X 20
Nut	17	M10
Clips	2	90 X 30

2 Collector 1808		
No	Unit	Dimensions
1L	1	3 screwed pieces of (1490 - 1190- 980) X 40 X 40 mm
2L	1	3 screwed pieces of (1490 - 1190- 980) X 40 X 40 mm
3R	1	2 screwed pieces of 1670 X 30 X 5 mm
5U	1	2100 X 30 X 30 mm
5D	1	2100 X 30 X 30 mm
Screw	19	M10 X 20
Nut	19	M10
Clips	4	90 X 30

1 Collector 2108		
No	Unit	Dimensions
1L	1	3 screwed pieces of (1490 - 1190- 980) X 30 X 30 mm
2L	1	3 screwed pieces of (1490 - 1190- 980) X 30 X 30 mm
3R	1	2 screwed pieces of 980 X 30 X 5 mm
5U	1	1150 X 30 X 30 mm
5D	1	1150 X 30 X 30 mm
Screw	17	M10 X 20
Nut	17	M10
Clips	2	90 X 30

2 Collector 2108		
No	Unit	Dimensions
1L	1	3 screwed pieces of (1490 - 1190- 980) X 40 X 40 mm
2L	1	3 screwed pieces of (1490 - 1190- 980) X 40 X 40 mm
3R	1	2 screwed pieces of 1670 X 30 X 5 mm
5U	1	2300 X 30 X 30 mm
5D	1	2300 X 30 X 30 mm
Screw	19	M10 X 20
Nut	19	M10
Clips	4	90 X 30

1 Collector 2510		
No	Unit	Dimensions
1L	1	3 screwed pieces of (1490 - 1190- 980) X 30 X 30 mm
2L	1	3 screwed pieces of (1490 - 1190- 980) X 30 X 30 mm
3R	1	2 screwed pieces of 980 X 30 X 5 mm
5U	1	1335 X 30 X 30 mm
5D	1	1335 X 30 X 30 mm
Screw	17	M10 X 20
Nut	17	M10
Clips	2	90 X 30

2 Collector 2510		
No	Unit	Dimensions
1L	1	3 screwed pieces of (1490 - 1190- 980) X 40 X 40 mm
2L	1	3 screwed pieces of (1490 - 1190- 980) X 40 X 40 mm
3R	1	2 screwed pieces of 1670 X 30 X 5 mm
5U	1	2670 X 30 X 30 mm
5D	1	2670 X 30 X 30 mm
Screw	19	M10 X 20
Nut	19	M10
Clips	4	90 X 30

On Roof



Support (Black Painted)



Wood Screw



Screw



Nut

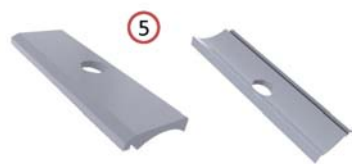

Clamp



Aluminum profile



See Aluminum profile dimensions table

	Part Name	Quantity	
		1 coll.	2 coll.
1	Support (Black Painted)	4	6
2	8 x 60 Wood Screw	8	12
3	M10 x 20 Screw	6	10
4	M10 Nut	6	10
5	Clamp	2	4
6	Aluminum profile	1	1
7	Aluminum profile	1	1

Aluminum profile dimensions (mm)			
Model	1 coll.		2 coll.
2510	1335 x 30 x 30	2670 x 30 x 30	2670 x 30 x 30
2108	1150 x 30 x 30	2300 x 30 x 30	2300 x 30 x 30
1808	1050 x 30 x 30	2100 x 30 x 30	2100 x 30 x 30

On Roof

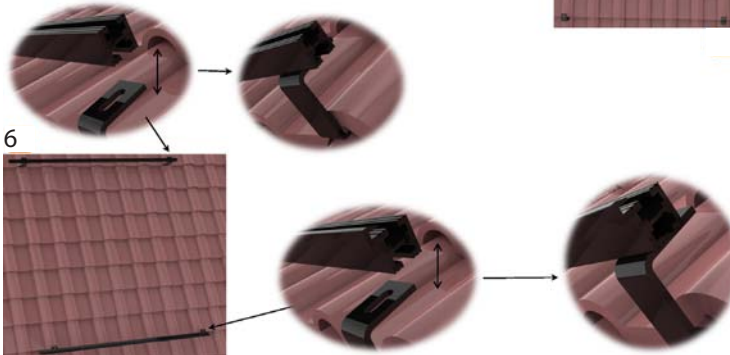
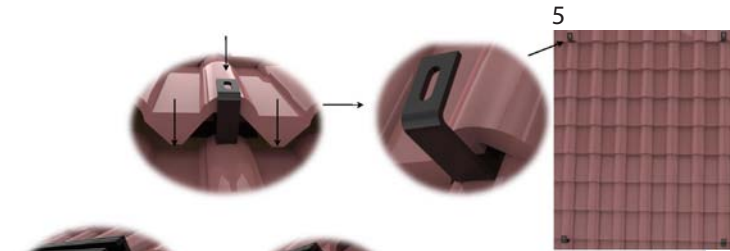
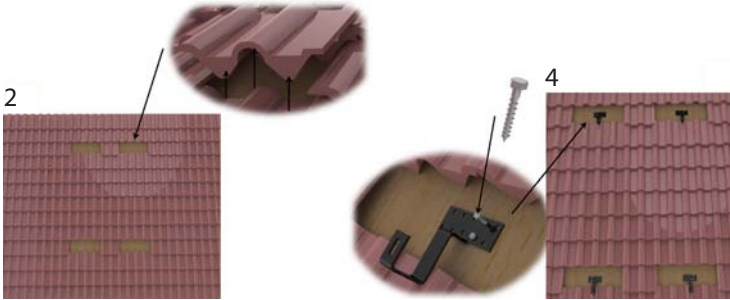

On Roof

7

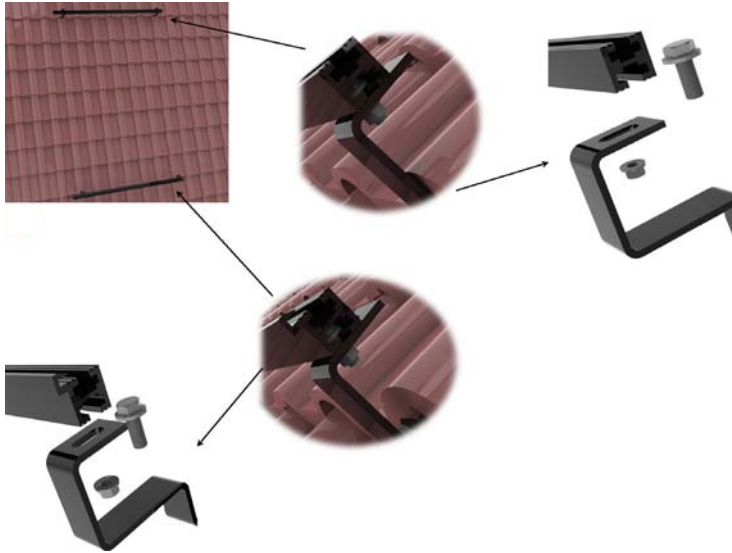

8

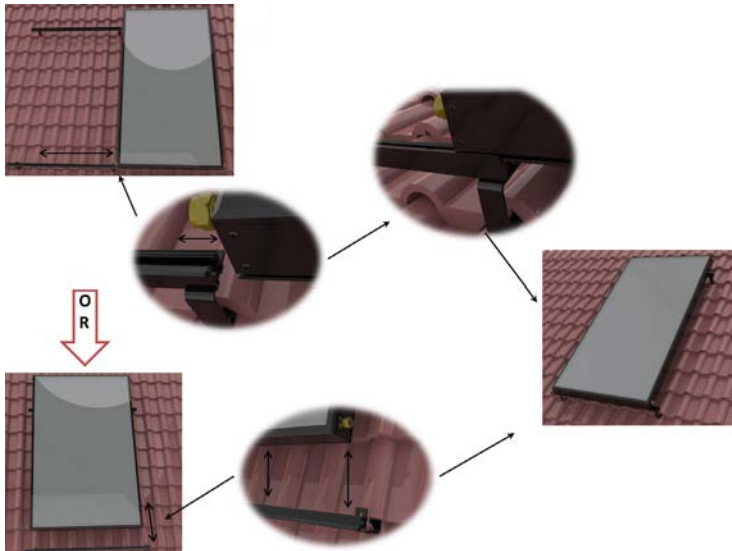

On Roof

9

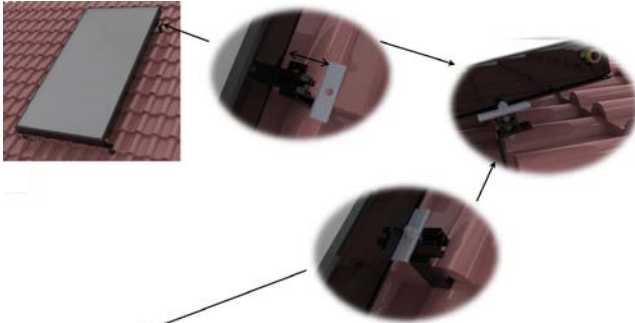

9a

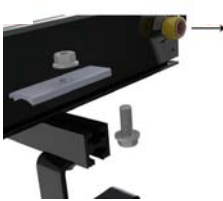

9b



9c



Finished Installation

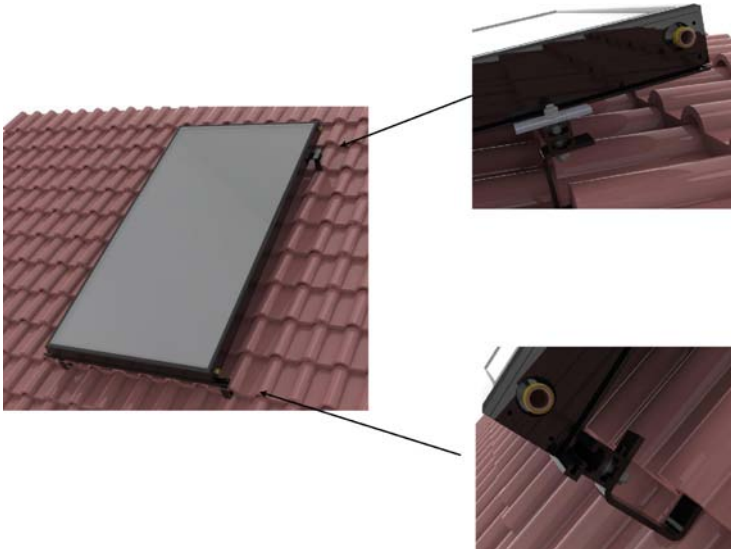

## In Roof Installation Guide

To ensure sufficient space for roof tiles to overlap the installation, in roof collectors should not be placed adjacent to chimneys or dorma windows

Roof type	Suitable?
Slate	Yes
Tiled	Yes
Double lap plain clay	Yes
Shingle	No
Seam	No
Concrete	No
Others	Contact Kingspan for more information

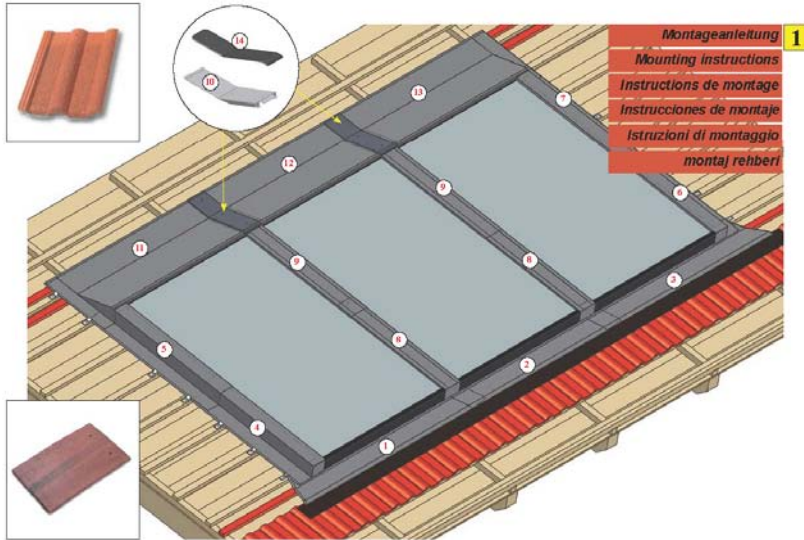

### Ready mounted dimensions

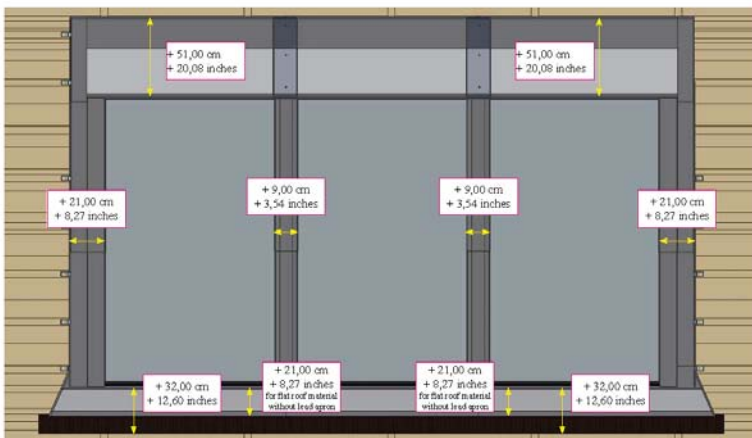

Before you start mounting the flashings please check the dimensions above, which show the ready mounted dimensions of the flashing. You have to add the dimensions of the flashing to the dimensions of the solar-panel so you will get the ready mounted dimension of the whole solar-system.

**This mounting instruction is valid for corrugated and flat roof tiles (for flat roof-tiles the foreparts are fabricated without lead-apron!!)**

In Roof

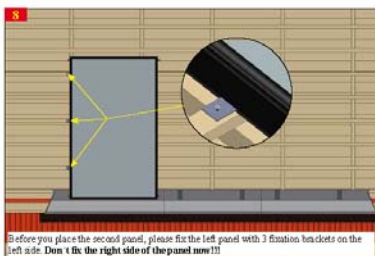
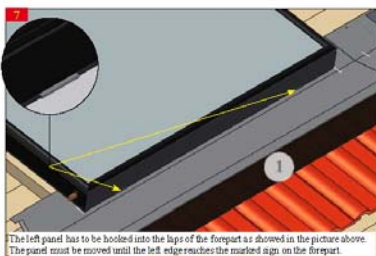
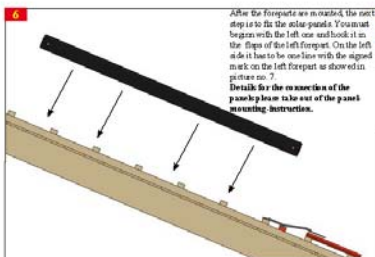
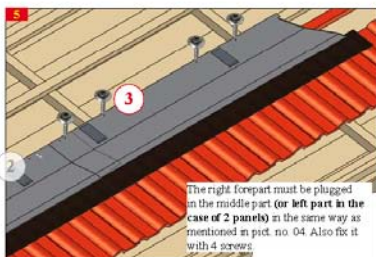
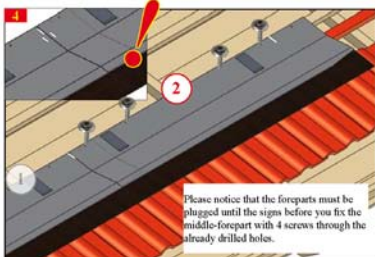
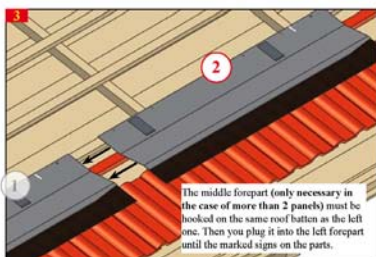
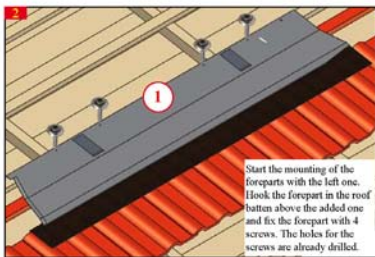
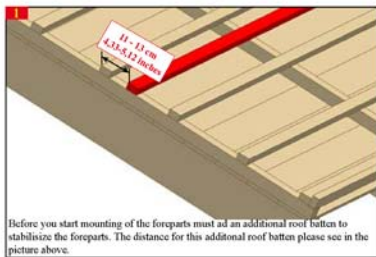

In Roof

5

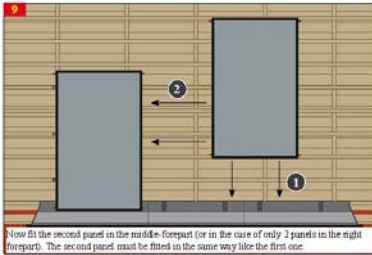

Now fit the second panel in the middle-forepart (or in the case of only 2 panels in the right forepart). The second panel must be fitted in the same way like the first one.



After you have placed the second panel, fix it with the longer fixation brackets to gather with the right side of the first panel. See the detailed picture on the right side. If you have only a 2-panel-system you can start fixing the right side of the second panel, in the same way as the left side of the first panel.

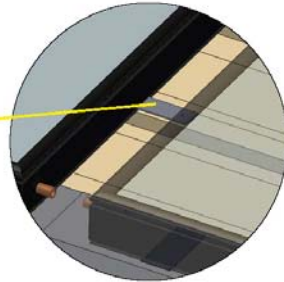

The mounting of a 3rd or further panels works in the same way as explained in the last points.

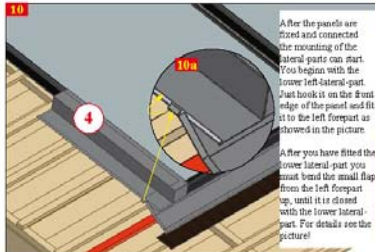

After the panels are fixed and connected the mounting of the lateral parts can start. You begin with the lower left-lateral part. Just hook it on the front edge of the panel and fit it to the left forepart as showed in the picture.

After you have fitted the lower lateral part you must bend the small flap from the left forepart up, until it is closed with the lower lateral part. For details see the picture!

6

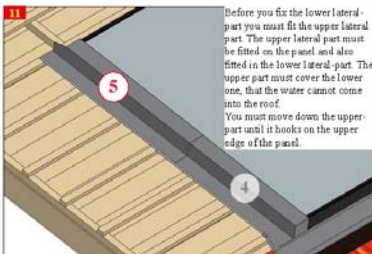

Before you fix the lower lateral part you must fit the upper lateral part. The upper lateral part must be fitted on the panel and also fitted in the lower lateral part. The upper part must cover the lower one, that the water cannot come into the roof. You must move down the upper part until it hooks on the upper edge of the panel.

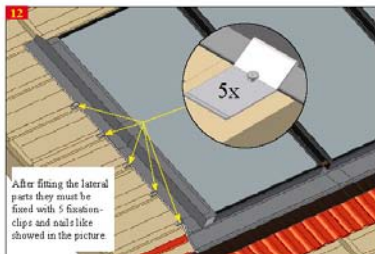

After fitting the lateral parts they must be fixed with 5 fixation clips and nuts like showed in the picture.

7

In Roof

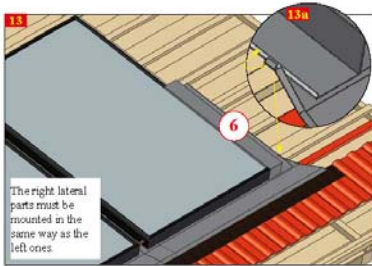

The right lateral parts must be mounted in the same way as the left ones

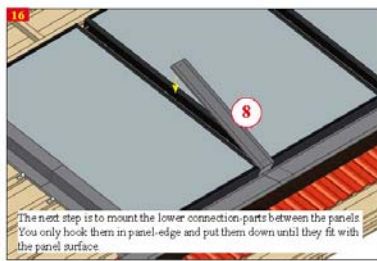
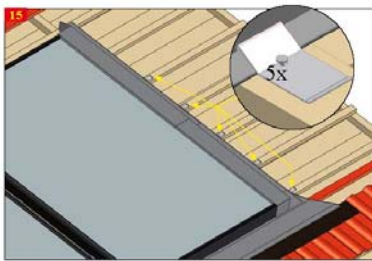
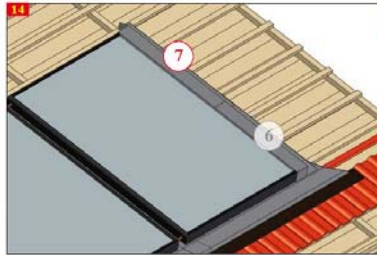

The next step is to mount the lower connection-parts between the panels. You only hook them in panel-edge and put them down until they fit with the panel surface.

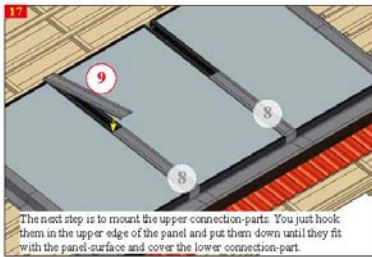

The next step is to mount the upper connection-parts. You just hook them in the upper edge of the panel and put them down until they fit with the panel-surface and cover the lower connection-part.

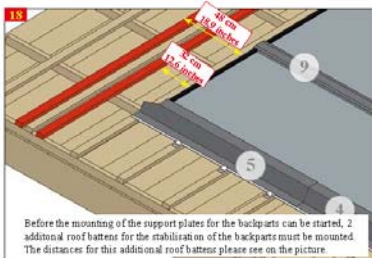
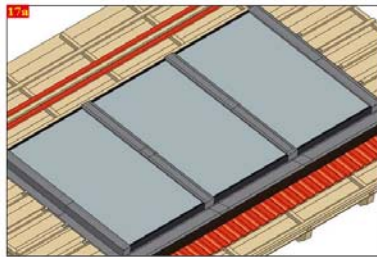

Before the mounting of the support plates for the backparts can be started, 2 additional roof battens for the stabilisation of the backparts must be mounted. The distances for this additional roof battens please see on the picture.

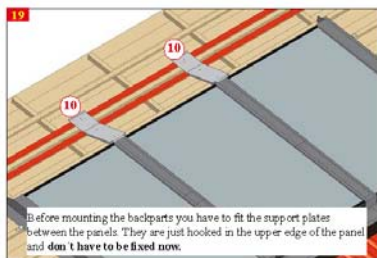

Before mounting the backparts you have to fit the support plates between the panels. They are just hooked in the upper edge of the panel and **don't** have to be fixed now.

In Roof

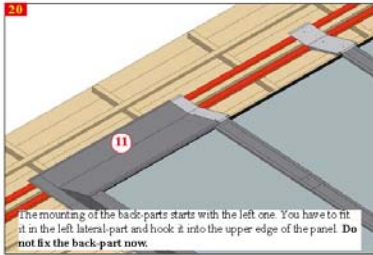

The mounting of the back-parts starts with the left one. You have to fit it in the left lateral-part and hook it into the upper edge of the panel. **Do not fix the back-part now.**

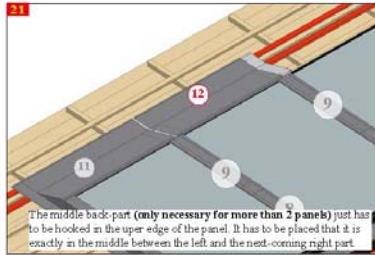

The middle back-part (only necessary for more than 2 panels) just has to be hooked in the upper edge of the panel. It has to be placed that it is exactly in the middle between the left and the next-coming right part.

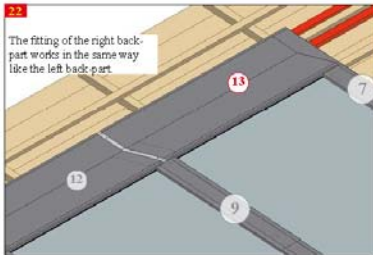

The fitting of the right back-part works in the same way like the left back-part.

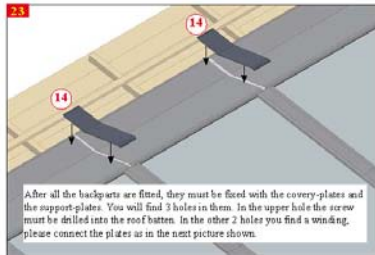

After all the back-parts are fitted, they must be fixed with the cover-plates and the support-plates. You will find 3 holes in them. In the upper hole the screw must be drilled into the roof-batten. In the other 2 holes you find a winding, please connect the plates as in the next picture shown.

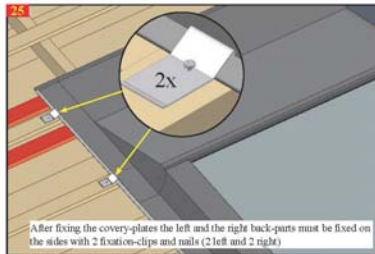
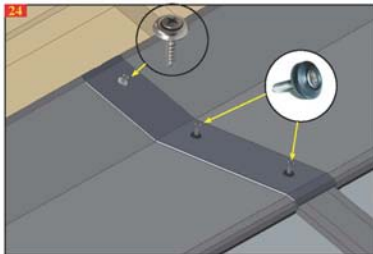

After fixing the cover-plates the left and the right back-parts must be fixed on the sides with 2 fixation-clips and nails (2 left and 2 right).

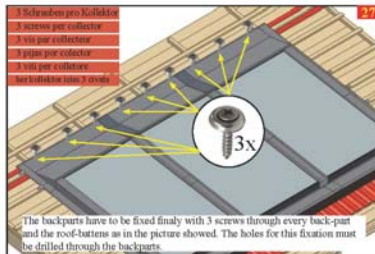
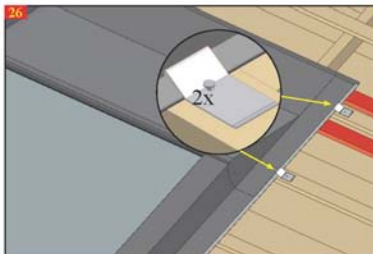

- 3 Schrauben pro Kollektor
- 3 screws per collector
- 3 vis per collecteur
- 3 parafus per collectore
- 3 шурупы на каждый коллектор

The back-parts have to be fixed finally with 3 screws through every back-part and the roof-battens as in the picture showed. The holes for this fixation must be drilled through the back-parts.

## In Roof

17

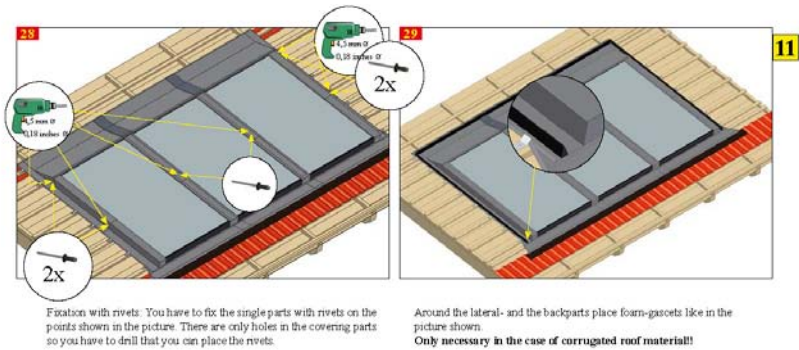

- Please ensure roof tiles overlap the side edges and top of collector to ensure watertight seal
- Please ensure skirt at bottom of cassette overlaps tiles to ensure watertight seal and rainwater run-off.

Interconnection

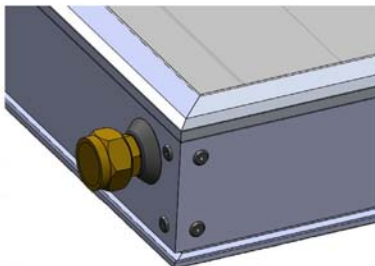
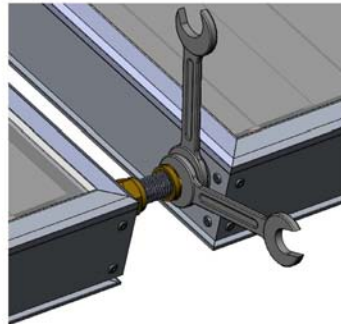
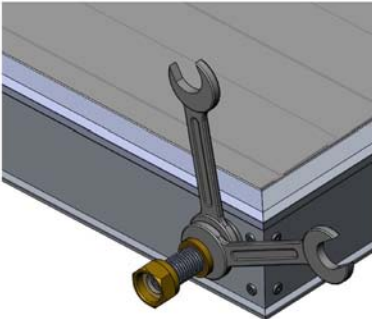
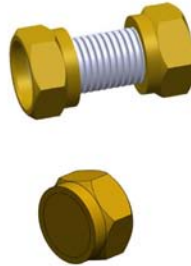
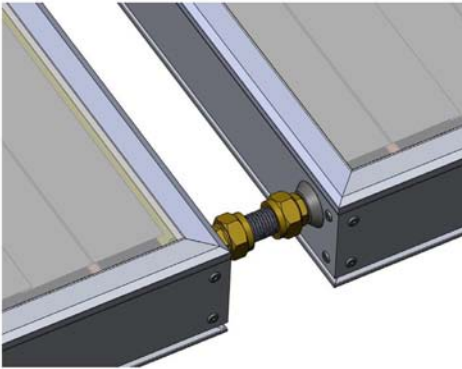

## Connecting the Collector

In any solar panel system, the 'return' refers to the intake in the collector where liquid is returning to be reheated. The 'flow' refers to the collector side where the liquid is flowing to the heat

Note: It is essential that the collector temperature sensor is located on the same side as the flow of the collector.

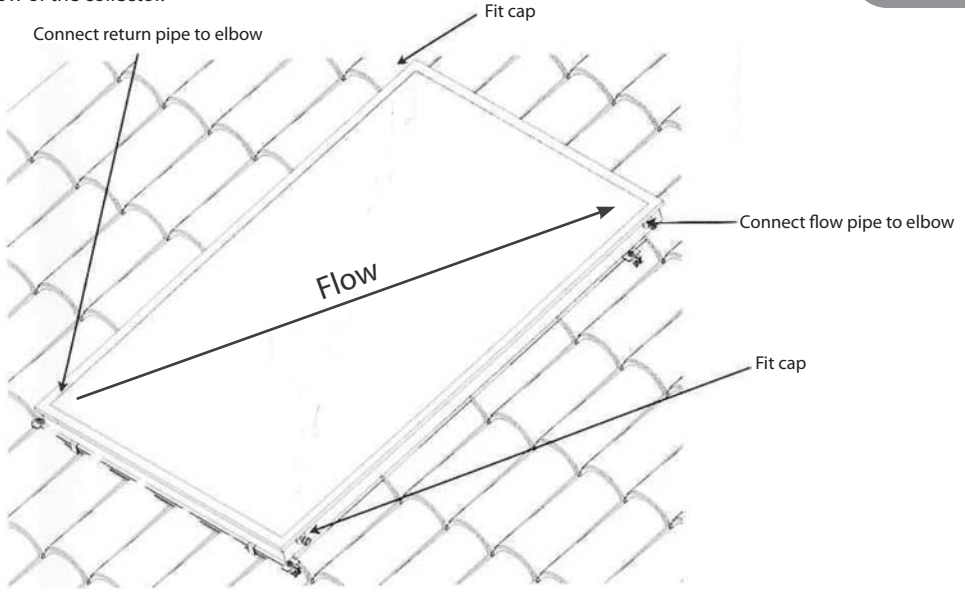

### Connecting 1st fix kit

- |  |                          |
|--|--------------------------|
| 1. 3/4" BSP female to 3/4" male elbows | 4. 3/4" stop ends        |
| 2. 3/4" washers                        | 6. PT1000 sensor         |
| 3. AZ DN16 hose 2m preassembled        | 11. Sensor retaining cap |

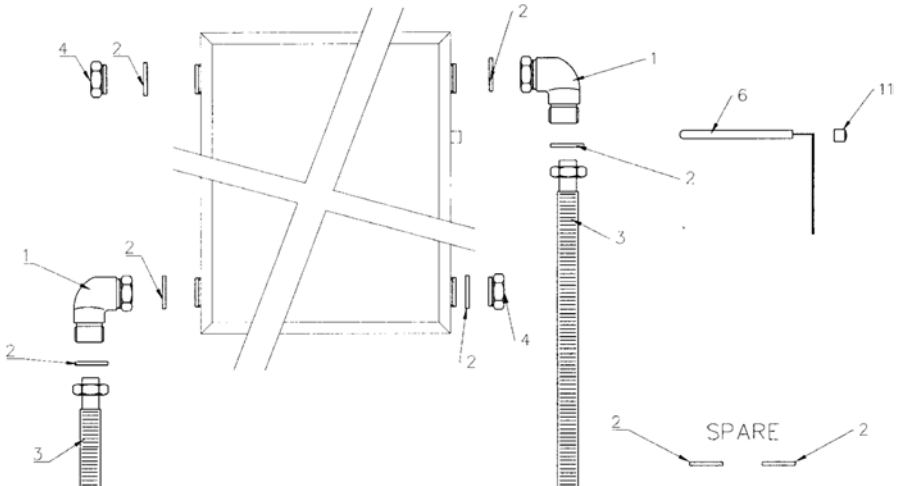

## Connecting the Collector

For a dual collector installation the collector panels should be joined in the centre using the supplied interconnection fittings (2 off). The solar fluid return pipe should be connected to the lower collector port (either left or right). The solar fluid flow pipe should then be connected to the opposite upper collector port (either right or left depending on the return pipe connection). The 2 remaining ports that are not in use should be capped. An installation with the solar fluid return pipe connected to the lower left port and the solar fluid flow pipe connected to the upper right port is shown below.

For larger scale systems up to 8 panels can be connected in series by the method described above. For design of larger scale solar system please contact Kingspan Solar.

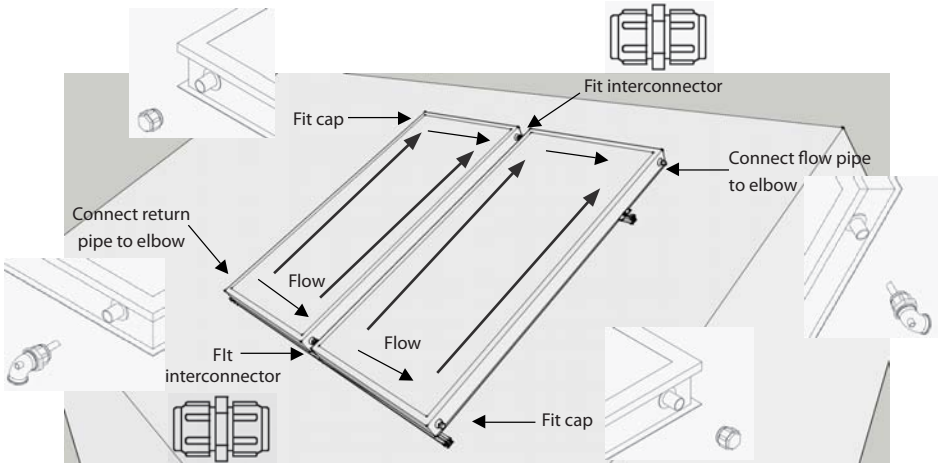

Lastly, insert the sensor into the sensor pocket integrated into the panel. The sensor is held in position by cutting a small hole in the rubber cap and passing the sensor head and cable through the hole. The rubber cap, sensor and cable is then attached to the integrated sensor pocket

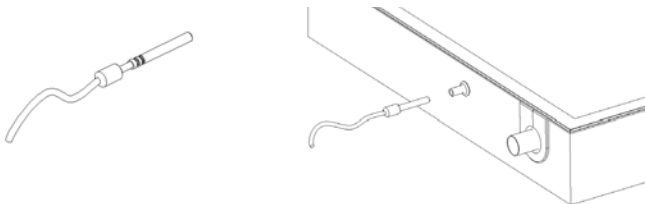

## Types of Connections

The only pipes which should be used with a solar installation are copper pipe, continuous flexible stainless steel or mild steel.

When using copper pipe, only compression or brazed joints can be used. Solder and galvanised fittings will not withstand high temperature or expansion and are therefore not suitable for solar pipe work.

**PEX / PLASTIC / PEX-ALU-PEX or GALVANISED TUBING OR FITTINGS  
SHOULD NOT BE USED UNDER ANY CIRCUMSTANCES**

## Flexible Pipe Connections

Flexible pipe connections are recommended to connect the manifold through the building fabric and allow flexibility in connecting to the internal pipe work.

Flexible stainless steel pipes are available in both a 15mm and 22mm diameter. If connecting one diameter pipe to another, a suitable reducer compression fitting is recommended to make the connection.

## Insulation

All pipe work on the solar loop should be insulated with high temperature insulation (such as HT/Armaflex from Armacell GmbH). High temperature insulation is essential as regular pipe insulation will melt at temperatures experienced by solar pipes.

The wall thickness of the insulation should be equal to the diameter of the pipe. The only pipes which should not be insulated are the pipes to the safety vessels as they should allow heat to dissipate when the system is experiencing excessive heat and pressure.

## Pump Station

The Kingspan Solar product range offers both a single stream and a dual stream pump station. Each pump station is available in two flow rates, 2-12 litres and 8-28 litres.

The flow rate required on a system is typically 1 litre per minute, per square metre installed. Therefore a 2-12 litre pump station will be sufficient for systems up to 12m<sup>2</sup>. 7 collectors (see table below)

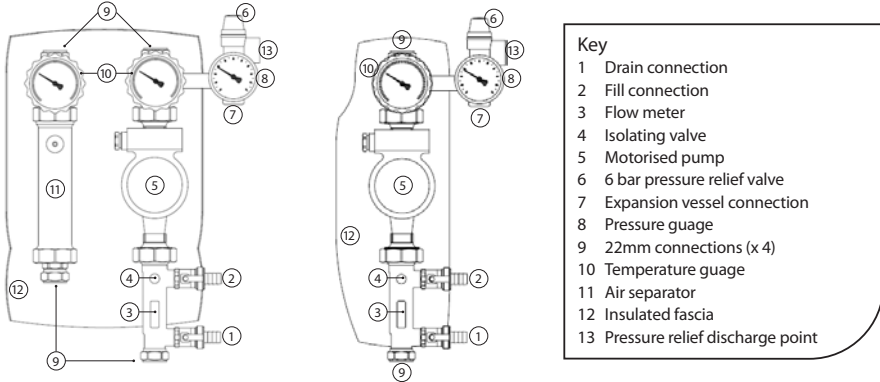

Connections of flow and return pipe work to the pump station are made with the straight compression fittings provided for direct copper connection.

	Recommended Maximum Number of Panels in Series		
Pump Station	Kingspan Solar 1808	Kingspan Solar 2108	Kingspan Solar 2510
2-12 lpm	7 collectors	6 collectors	6 collectors

### Fitting the expansion vessel:

It is recommended that the expansion vessel is located below the level of the connection from the pump station to prolong its life.

The expansion vessel supplied includes an appropriate corrugated hose and threaded connection to join the vessel to the pump station.

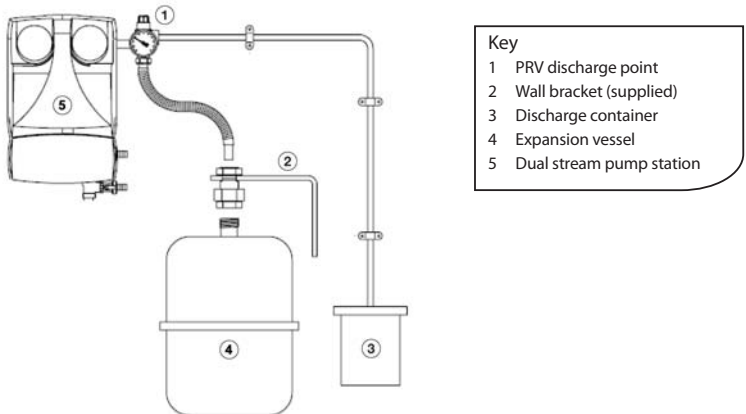

## Safety Vessel Connections

### Pressure Relief Valve (PRV)

Rated at 6 bar, the PRV may discharge heat transfer fluid which must be channelled into a container capable of withstanding high temperature discharge and containing the total collector volume. The container should be secured so it cannot be removed or spilled.

Kingspan Solar offers a plastic (PE) discharge tank, withstanding temperatures up to 160°C - see picture.

The PRV should not be channelled into a drain or any pipe work which will allow it to enter the normal water course.



Solar fluid discharge tank (KSP0125)

### Fitting the expansion vessel:

It is recommended that the expansion vessel is located below the level of the connection from the pump station to prolong its life.

The expansion vessel supplied includes an appropriate corrugated hose and threaded connection to join the vessel to the pump station.

## Wiring the Solar Control Panel

All electrical aspects of the installation should be undertaken by a qualified electrician. Note that for safety, the pump and sensor connections should always be wired prior to connecting power to the solar control panel.

**IMPORTANT:** The solar control panel must have a permanent electrical power supply which must not be interrupted either manually or with a time switch. If the permanent electrical supply to the building is to be switched off for any period of time, the solar collector(s) should either be covered, or the system drained and the tubes removed.

In order to protect the normal operation of the control panel, it should be located at least 100 mm from insulated pipes which may become hot during operation.

Control panels use PT1000 sensors containing twin core copper cable with a 0.75mm cross section. The sensors supplied are 1.5 metres in length.

Sensor cables can be extended with twin core copper cable of 0.75mm diameter up to 50 metres and 1.50mm diameter between 50-100m. Screened cable should be used on the sensor cables to prevent RFI from electrical cables. All connections to extend the cables should be housed in a junction box for protection.

The following diagrams show the connection of the solar pump and other relays on the SC range of controllers. This should be read in conjunction with the Installation and Operation Manual supplied with each SC control panel.

### Power Supply Connection:

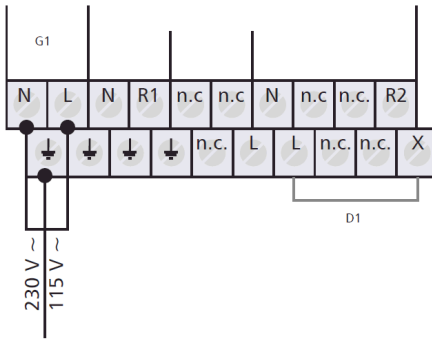

### Sensor Connection

The connection of PT1000 sensors is as shown below. The polarity of the sensor cables is not relevant on each sensor. The SC100 has four inputs as illustrated below. However the SC200 and SC300 can receive five and six sensors respectively (for larger system design) and are connected in the same way.

Input connection for 1-4 sensors:

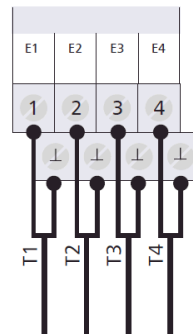

### Connection of first output/pump (R1)

R1 of the SC controllers comprises a semiconductor relay (TRIAC), also suitable for RPM control with a maximum switching current displayed on the unit type plate. Both the SC100 and the SC200 contain an electromechanical relay, R2.

Note that the SC300 contains two RPM relays, R1 and R2 as well as an electromechanical relay, R3. The SC200 and SC300 are therefore suitable for controlling two pumps i.e. for an east/west panel array or a stagnation configuration requiring a second pump.

#### Caution

Avoiding damage and malfunctions – When connecting an external relay or contactor, or when connecting a pump which has its own electronic RPM control, the controller output's RPM control must be deactivated (see "Setting the RPM control parameters" in the Controller Manual).

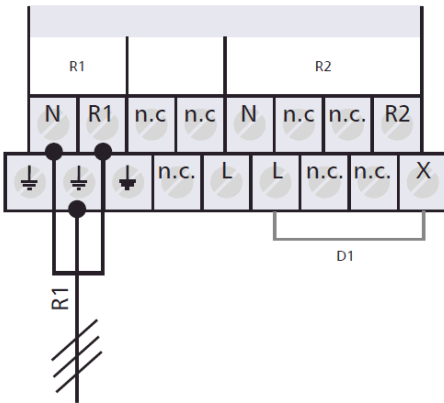

### Connection of second output (R2) if required

R2 on the SC100 contains a switched output via an electromechanical relay with a maximum switching current displayed on the unit type plate. Note the wire bridge (D1) must be connected.

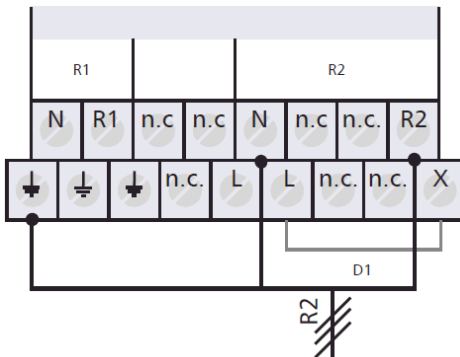

## Commissioning the System

### Installing the collectors

The collectors should be installed at a time when there is very low light such as late afternoon when the sun is low and not particularly strong. Alternatively the collectors should be covered. This is important as tube connections can heat up considerably in a short space of time and have potential to cause injury while the glass temperature will remain low.

### Expansion Vessel

**IMPORTANT:** Prior to filling the system, the expansion vessel pressure must be set 0.3 Bar below the system pressure. Omitting to perform this check will result in irregular pressure readings during the commissioning of the system.

The pressure is checked at the base of the vessel and the bleed valve may be bled or topped up with a pump.

### Filling the Loop

It is important that a motorised flush and fill centre is used to fill and pressurise the system with the kingspan recommended thermal fluid as follows:

1. Open the fill and drain valves to allow the liquid to circulate around the solar loop
2. Turn the hot and cold temperature gauges 45° clockwise.
3. Close the isolating valve above to the flow meter to ensure all air and liquid passes through the fill centre to filter any air and contaminants.
4. Run the fill centre pump to circulate the thermal fluid for approximately 20 minutes.
5. Open and close the isolating valve intermittently to circulate air bubbles which may accumulate in the sight glass.
6. Return isolating valve to closed position.
7. When the solar loop has been purged of air, close the bottom/drain connection – the fill centre will begin to pressurise the solar loop
8. Reopen the isolating valve above the flow meter fully.
9. Fill the loop until the pressure gauge just exceeds the required pressure and stop the pump and immediately close the fill connection. Check pipe joints on the solar loop for leaks and check that pressure is not lost over a 30 minute period.
10. If all the plumbing is sound, set the system pressure by opening the return connection until the required pressure is met.
11. Return the temperature gauges to the original position.
12. The fill centre may now be disconnected.
13. Cap the fill and drain points with the brass covers provided.

The pipes from the flush and fill centre should be connected as shown in the diagram below:

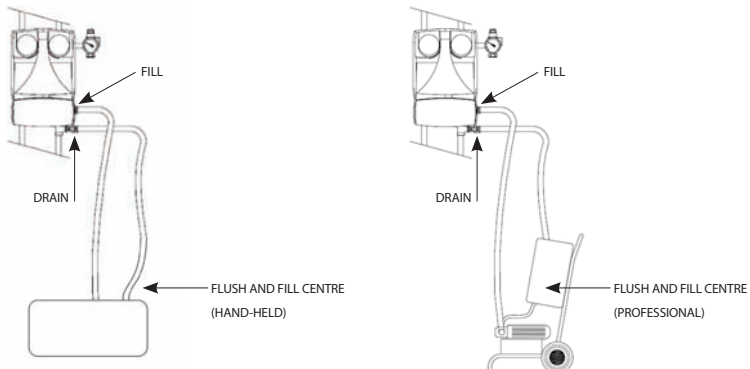

## Setting the flow rate

The pump may only be run when the system has been filled as dry operation will damage the pump. The desired flow rate is typically 0.8 litres per minute per m<sup>2</sup> (Depends on panel). The desired flow rate is given in table A below.

1. Set the pump to the first speed and run it manually from the controller (see following paragraph).
2. If the desired flow rate is exceeded, set the flow meter to the desired rate by adjusting the isolating valve with a flat headed screwdriver (see diagram) with the pump running. Otherwise repeat this step at the next pump speed and continue until the desired flow rate is achieved
3. Stop the pump.

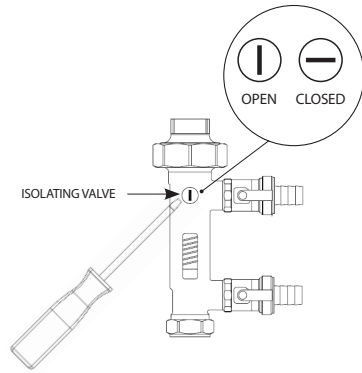

Left side view of controller

### Operating switch

The following modes of operation can be selected:

- **Manual** for commissioning and testing for function
- **Automatic** for automatic operation
- **Off** for switching off the outputs



## Operating the pump in 'Manual' mode (for SC range controllers)

In order to run the pump in 'Manual' mode, slide the operating switch on the left side of the solar control panel to the upper of the three positions. On the screen, select the appropriate relay with the up/down arrows and press the 'Set' button to run the relay and to switch it off again.

## Other Relays

If any additional relays are set up on the system, these should be tested in 'Manual' mode as above, to ensure the connections have been wired correctly.

Table A

KINGSPAN SOLAR FLATPLATE COLLECTORS									
RECOMMENDED FLOW RATES									
Field Size No. of Collectors	Standard Flow Conditions			Adapted Flow Conditions			Low Flow Conditions		
	1808 l / min	2108 l / min	2510 l / min	1808 l / min	2108 l / min	2510 l / min	1808 l / min	2108 l / min	2510 l / min
1	1.7	1.8	2.0	1.1	1.2	1.3	0.8	0.9	1.0
2	3.3	3.5	4.0	2.2	2.3	2.7	1.6	1.8	2.1
3	5.0	5.3	6.0	3.3	3.5	4.0	2.3	2.7	3.1
4	6.7	7.0	8.0	4.3	4.7	5.3	3.1	3.6	4.2
5	8.4	8.8	10.0	5.4	5.9	6.7	3.9	4.5	5.2
6	10.0	10.5	12.0	6.5	7.0	8.0	4.7	5.3	6.2
7	11.7	12.3	14.0	7.6	8.2	9.4	5.5	6.2	7.3
8	13.4	14.0	16.0	8.7	9.4	10.7	6.2	7.1	8.3
9	15.0	15.8	18.0	9.8	10.5	12.0	7.0	8.0	9.4
10	16.7	17.5	20.0	10.8	11.7	13.4	7.8	8.9	10.4
11	18.4	19.3	22.0	11.9	12.9	14.7	8.6	9.8	11.4
12	20.0	21.0	24.0	13.0	14.0	16.0	9.4	10.7	12.5
13	21.7	22.8	26.0	14.1	15.2	17.4	10.1	11.6	13.5
14	23.4	24.5	28.0	15.2	16.4	18.7	10.9	12.5	14.6
15	25.1	26.3	30.0	16.3	17.6	20.0	11.7	13.4	15.6
16	26.7	28.0	32.0	17.3	18.7	21.4	12.5	14.2	16.6
17	28.4	29.8	34.0	18.4	19.9	22.7	13.3	15.1	17.7
18	30.1	31.5	36.0	19.5	21.1	24.0	14.0	16.0	18.7
19	31.7	33.3	38.0	20.6	22.2	25.4	14.8	16.9	19.8
20	33.4	35.0	40.0	21.7	23.4	26.7	15.6	17.8	20.8

**NOTE :** It is only recommended to connect a maximum of 8 collectors in series.  
For low flow conditions / high temperature applications the number of collector in series should be < 8  
Please contact Kingspan Renewables for advice on system sizing requirements if required.

## Decommissioning the System

Due to temperatures potentially exceeding 170°C and pressures greater than 6 bar, a solar installation should only be decommissioned by a trained individual. The system should be decommissioned in low light, ideally in the morning when the solar loop should be coolest.

### 1. Electrical

- Isolate controller from mains
- Remove cables to consumer units  
i.e. controller and pump
- Remove sensors and associated cables
- Remove earthing cables

### 2. Collector Loop

- Beware of hot transfer fluid
- Drain collector loop at drain valve.  
Contain the heat transfer fluid for appropriate disposal.
- Disconnect pipes from the manifold

### 3. Collector (Beware of high temperatures)

- Remove rubber retainer to release manifold lid
- Unclip tube
- Remove the rubber support retainers from around glass tube
- Remove tube manifold clip
- Remove tubes from manifold
- Remove lid and separate materials
- Remove Manifold and support rails and separate materials
- Remove roof kit and separate materials
- Reinstate roof

### Disposal

Dispose of separate materials in accordance with local regulations. Please see the following pages for details of materials used in the construction of Thermomax collectors and guidance on disposal of antifreeze.

## Disposal of Solar Anti-Freeze Solution

The solution we supply with our solar systems is a thermal transfer fluid based on 1,2 propylene glycol and water. The solution also contains corrosion inhibitors and has been specifically designed for use in solar systems with elevated temperatures, such as those experienced with Vacuum Tube Collectors.

Propylene Glycol is a widely used ingredient in pharmaceutical, food, cosmetic, personal care, flavours and animal feed applications. Propylene glycol is not volatile, but is miscible with water. Propylene glycol is not harmful to aquatic organisms and is readily biodegradable; however the disposal of the solution should be done in a responsible manner taking into consideration local Environmental and Health & Safety legislation.

While the solution is not subject to registration as a hazardous material according to EEC directives the solution should be disposed of by special means. There are a number of specialist companies that can deal with the disposal of propylene glycol. A list of these companies is available upon request. A copy of the EEC Safety Data sheet and Technical Information sheet is available upon request. We recommend that you contact your local authority to check that they will accept the solution at special landfill collection points.



## Warranty Statement

### Kingspan Renewables Ltd Warranty Statement for Solar

Subject to the following provisions, Kingspan Renewables Ltd warrants that the Goods will be free from defects in material and workmanship for a period of 10 years in relation to KINGSPAN SOLAR FLATE PLATE COLLECTORS. The warranty is given by Kingspan Renewables Ltd subject to the following conditions:

- A. Kingspan Renewables Ltd shall be under no liability in respect of any defect in the Goods arising from any information drawing design or specification supplied by the Buyer
  - B. Kingspan Renewables Ltd shall be under no liability in respect of any defect arising from fair wear and tear, wilful or accidental damage, negligence, abnormal working conditions, failure to follow the Kingspan Renewables Ltd design and installation instructions, misuse or alteration or repair of the Goods without approval
  - C. The above warranty does not extend to parts materials equipment not manufactured by Kingspan Renewables Ltd in respect of which the Buyer shall only be entitled to the benefit of any such warranty or guarantee as is given by the manufacturer to the Company.
  - D. The defect has been reported by the Buyer to Kingspan Renewables Ltd within the warranty period
  - E. The installation of the Goods having been carried out by fully trained and competent person(s)
  - F. The Goods having been subjected to neither "prolonged stagnation conditions" nor exhibiting signs of "extreme temperature exposure"
1. The Buyer shall not make any statement or representation or give any warranty to any third party in respect of any Goods other than in the terms made or given by Kingspan Renewables Ltd to the Buyer nor shall the Buyer have any authority to commit Kingspan Renewables Ltd to provide any service in relation to the Goods.
  2. The Company's liability to the Buyer for death or injury resulting from its own or that of its employees' agents' or subcontractors' negligence and damage suffered by the Buyer as a result of any breach of the obligations implied by Section 12 of The Sale of Goods Act 1979 shall not be limited.
  3. If Kingspan Renewables fails to deliver the Goods for any reason other than any cause beyond the Company's reasonable control or the Buyer's fault then Kingspan Renewables Ltd shall only be liable to the Buyer for and the Company's liability shall be limited to the excess (if any) of the cost to the Buyer (in the cheapest available market) of similar goods to replace those not delivered over the Price of the Goods.
  4. The Buyer shall examine all delivered Goods forthwith. Any claim based on any defect in the quality or condition of the Goods or their failure to correspond with specification shall be notified to Kingspan Renewable Ltd within 7 days from the delivery date or where the defect was not apparent on reasonable inspection within a reasonable time after discovery of the failure. If delivery is not refused and the Buyer does not notify Kingspan Renewable Ltd the Buyer shall not be entitled to reject the Goods.
  5. Kingspan Renewables Ltd shall be entitled to examine any Goods, which are the subject of any claim by the Buyer, and to remove such Goods or any part thereof for testing. No tests carried out by the Buyer will be recognised by Kingspan Renewables Ltd unless carried out strictly in accordance with a method previously agreed by Kingspan Renewables Ltd as being suitable for the purpose.
  6. Any valid claim in respect of the Goods which is based on any defect in the quality or condition of the Goods or their failure to meet specification is notified to Kingspan Renewables Ltd in accordance with these Conditions Kingspan Renewables Ltd shall be entitled to repair or replace the Goods (or the part in question) free of charge or at the Company's sole discretion refund to the Buyer the Price (or a proportionate part of the Price) but Kingspan Renewables Ltd shall have no further liability to the Buyer.
  7. Kingspan Renewables Ltd shall not be liable to the Buyer by reason of any representation (unless fraudulent) or any implied warranty condition or other term or any duty at common law (including but without limitation the negligence of Kingspan Renewables Ltd its employees agents or otherwise) or under the express terms of the Contract for any loss of production loss of profits or anticipated profits loss of contracts operation time or anticipated savings loss of business or of expected further business loss of or corruption to data damage to the Buyer's reputation or goodwill damages costs or expenses payable by the Buyer to any third party or any other indirect special or consequential loss or damage or claim (whether caused by the negligence of Kingspan Renewables Ltd its employees agents or otherwise) which arise out of or in connection with the supply of the Goods or their use or resale by the Buyer.
  8. Without prejudice to the provisions of clauses 3, 4, 5, 6 and 7 the entire liability of the Buyer under or in connection with the Contract shall not exceed the Price of the Goods.
  9. Kingspan Renewables Ltd shall not be liable to the Buyer or be deemed to be in breach of the contract by reason of any delay in performing or any failure to perform any of the Company's obligations in relation to the Goods if the delay or failure was due to any cause beyond the Company's reasonable control. Without limiting the foregoing, due to causes beyond the Company's reasonable control.
  10. For comprehensive details regarding "Warranties and Liability" please refer to the "CONDITIONS OF SALES" section 7.

This brochure is printed on environmentally friendly paper.



Kingspan Renewables have a policy of continuous product development and may introduce product modifications from time to time. As a consequence details given in this brochure are subject to alteration without notice.



## Kingspan Renewables

Tadman Street, Wakefield, West Yorkshire, WF1 5QU

Tel: +44 (0) 1924 376 026 Fax: +44 (0) 1924 375 015

E-mail: [sales@kingspansolar.co.uk](mailto:sales@kingspansolar.co.uk)

[www.kingspansolar.co.uk](http://www.kingspansolar.co.uk)

Issue 4 February 2012